

REV	DRWN	CHK'D	DATE	DESCRIPTION
A	GFC	GFC	3/7/03	INITIAL RELEASE
B	GFC	GFC	4/1/03	DESIGN CHANGE; ADDED NEW PARTS
C	GFC	GFC	4/28/03	REMOVED ITEM 9; ADDED ITEM 12

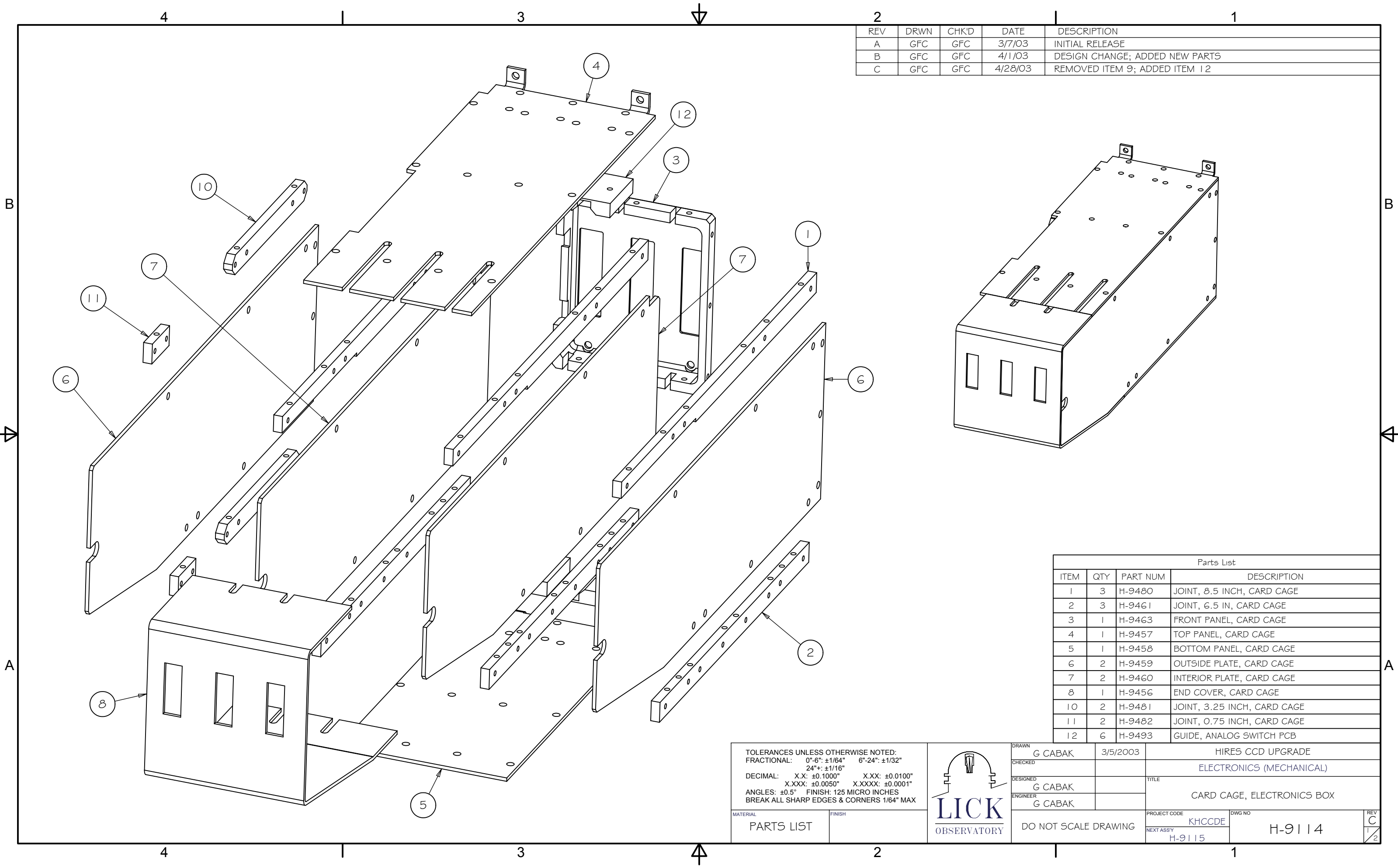

Parts List				
ITEM	QTY	PART NUM	DESCRIPTION	
1	3	H-9480	JOINT, 8.5 INCH, CARD CAGE	
2	3	H-9461	JOINT, 6.5 IN, CARD CAGE	
3	1	H-9463	FRONT PANEL, CARD CAGE	
4	1	H-9457	TOP PANEL, CARD CAGE	
5	1	H-9458	BOTTOM PANEL, CARD CAGE	
6	2	H-9459	OUTSIDE PLATE, CARD CAGE	
7	2	H-9460	INTERIOR PLATE, CARD CAGE	
8	1	H-9456	END COVER, CARD CAGE	
10	2	H-9481	JOINT, 3.25 INCH, CARD CAGE	
11	2	H-9482	JOINT, 0.75 INCH, CARD CAGE	
12	6	H-9493	GUIDE, ANALOG SWITCH PCB	

TOLERANCES UNLESS OTHERWISE NOTED:
 FRACTIONAL: 0"-6": ±1/64" 6"-24": ±1/32"
 24"+: ±1/16"
 DECIMAL: X.X: ±0.1000" X.XX: ±0.0100"
 X.XXX: ±0.0050" X.XXXX: ±0.0001"
 ANGLES: ±0.5° FINISH: 125 MICRO INCHES
 BREAK ALL SHARP EDGES & CORNERS 1/64" MAX

MATERIAL	FINISH
PARTS LIST	

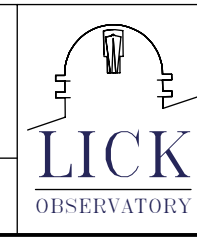

DRAWN G CABAK	3/5/2003	HIRES CCD UPGRADE	
CHECKED		ELECTRONICS (MECHANICAL)	
DESIGNED G CABAK		TITLE CARD CAGE, ELECTRONICS BOX	
ENGINEER G CABAK		PROJECT CODE KHCCDE	DWG NO H-9114
		NEXT ASSY H-9115	REV C 1/2

DO NOT SCALE DRAWING

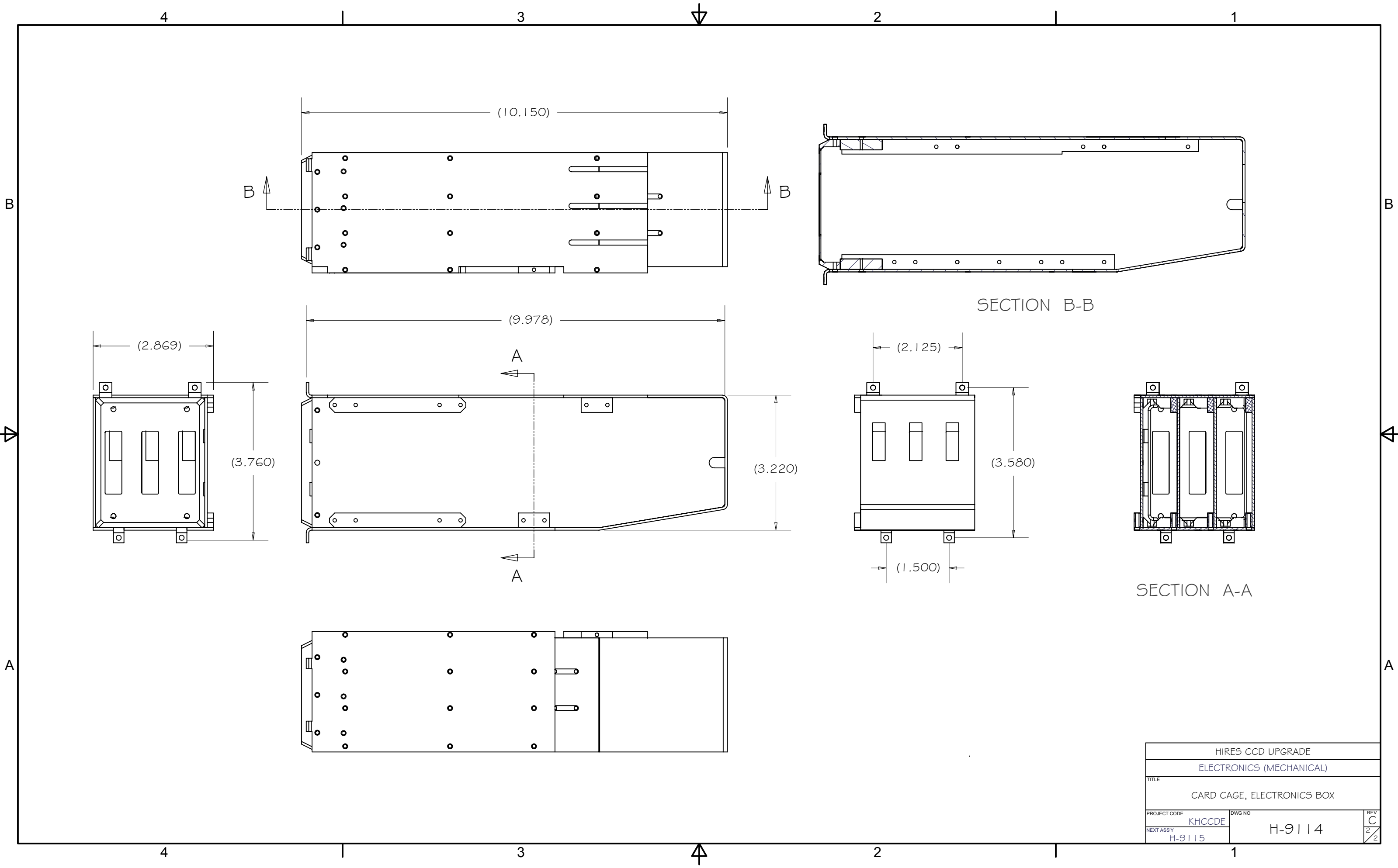

HIRES CCD UPGRADE			
ELECTRONICS (MECHANICAL)			
TITLE			
CARD CAGE, ELECTRONICS BOX			
PROJECT CODE	KHCCDE	DWG NO	REV
NEXT ASSY	H-9115	H-9114	C
			2/2