

8 7 6 5 4 3 2 1

REVISIONS				
DRWN	DATE	CHK'D	REV	DESCRIPTION
CR	11SEP15		A	PRELIMINARY RELEASE

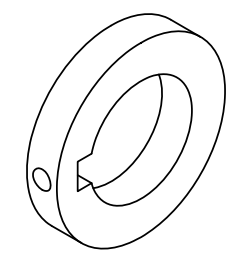
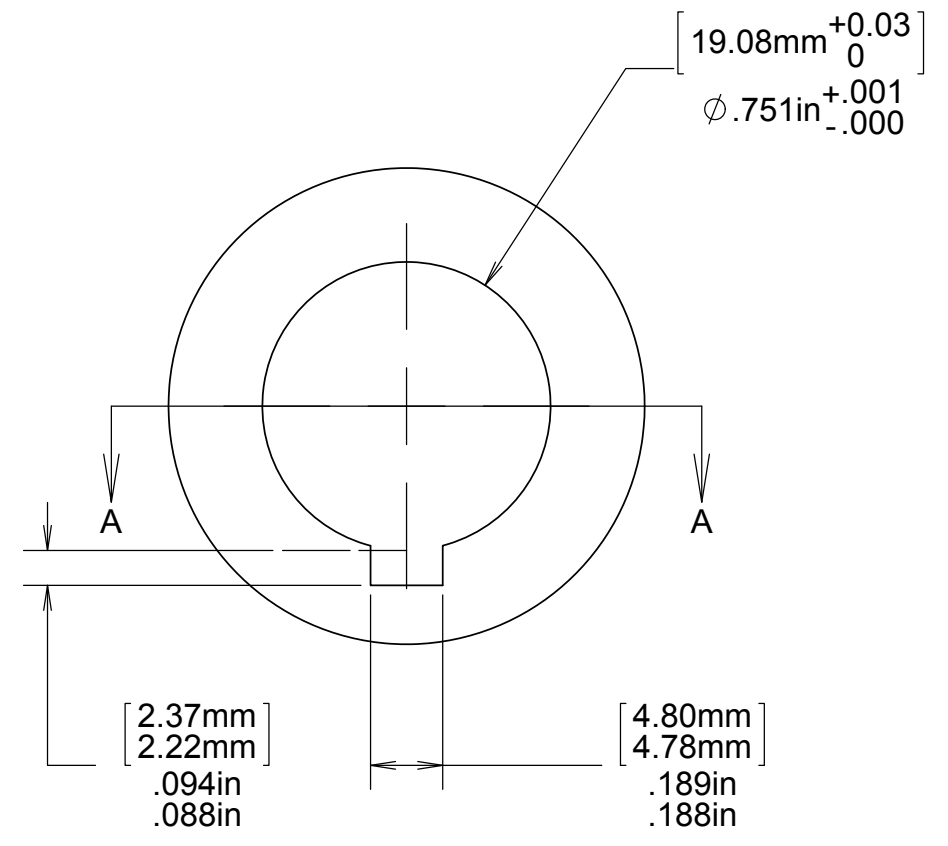
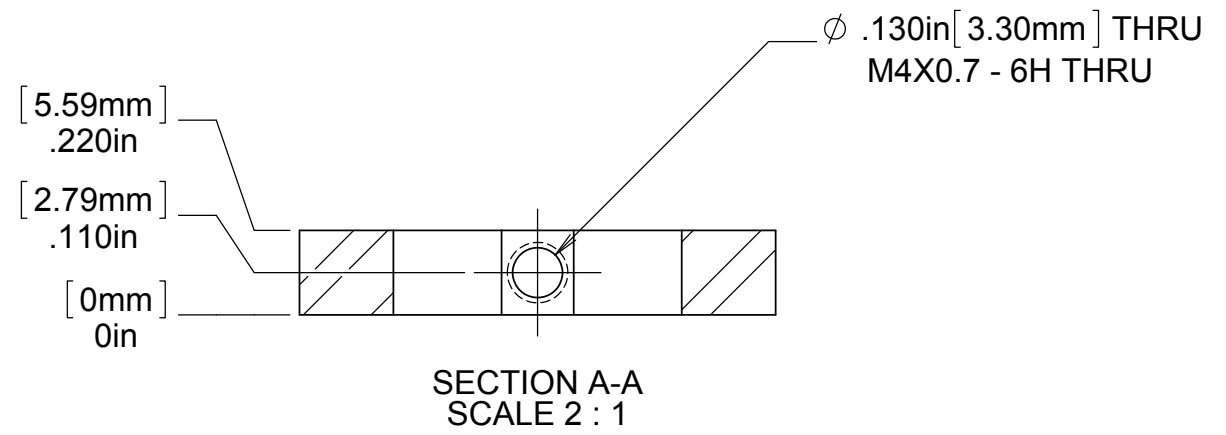

D
C
B
A

D
C
B
A

NOTES:
1. MATERIAL: FREE MACHINING STEEL OR SIMILAR

UNLESS OTHERWISE NOTED DIMENSIONS ARE IN MILLIMETERS & TOLERANCES ARE AS FOLLOWS: X: ±0.25mm X.X: ±0.20 mm X.XX: ±0.01 mm ANGLES: ±0.5° FINISH: 3 MICRONS (µm) BREAK ALL SHARP EDGES & CORNERS .25mm MAX			DESIGNED C. RATLIFF	PROJECT CODE K1D3DD	DWG NO KDM3112	REV A
MATERIAL SEE NOTES	FINISH NONE		CHECKED C. RATLIFF	DATE 9/11/15	TITLE GEAR COUPLING, SPACER B	QUANTITY 4 EA
			SW DOCUMENT FILE Spacer_Coupling_con tingB	NEXT ASSY KDM3100		

8 7 6 5 4 3 2 1