

REVISIONS				
DRWN	DATE	CHK'D	REV	DESCRIPTION
CR	26APR 16		A	PRELIMINARY RELEASE

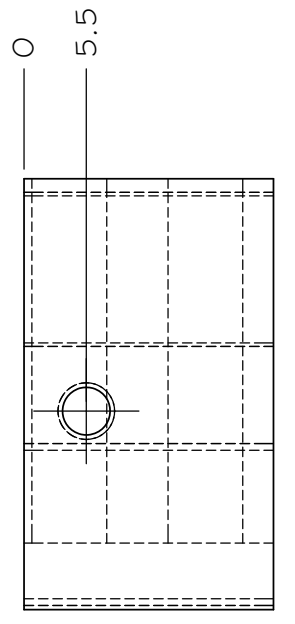
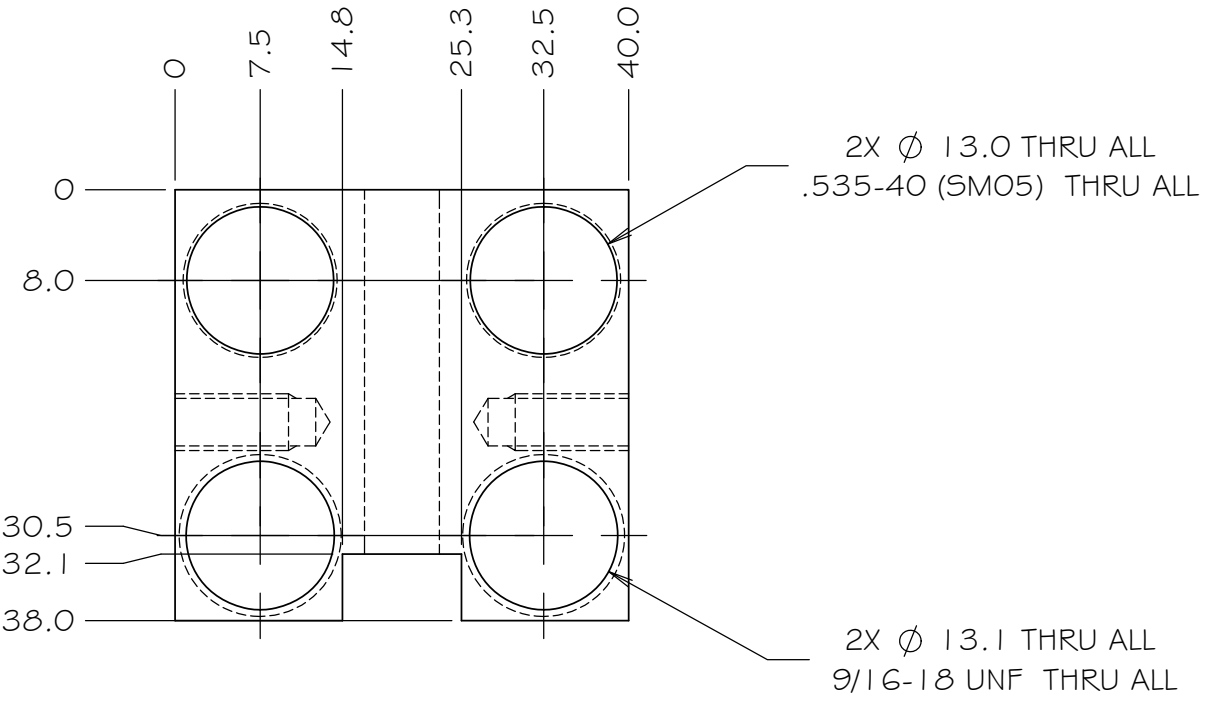
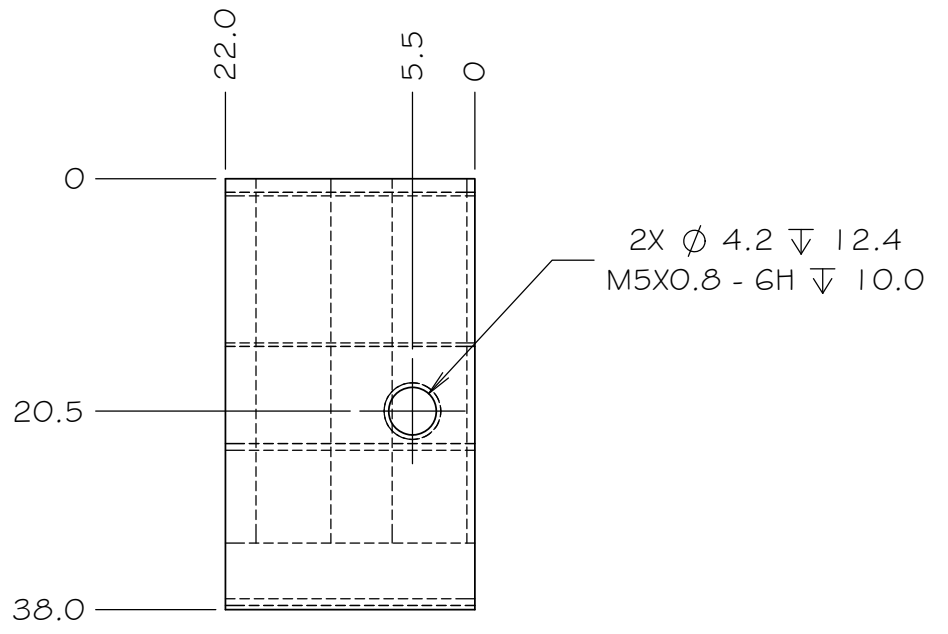
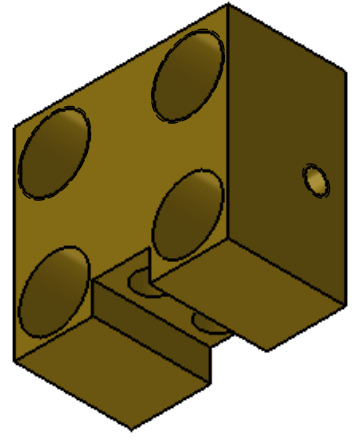
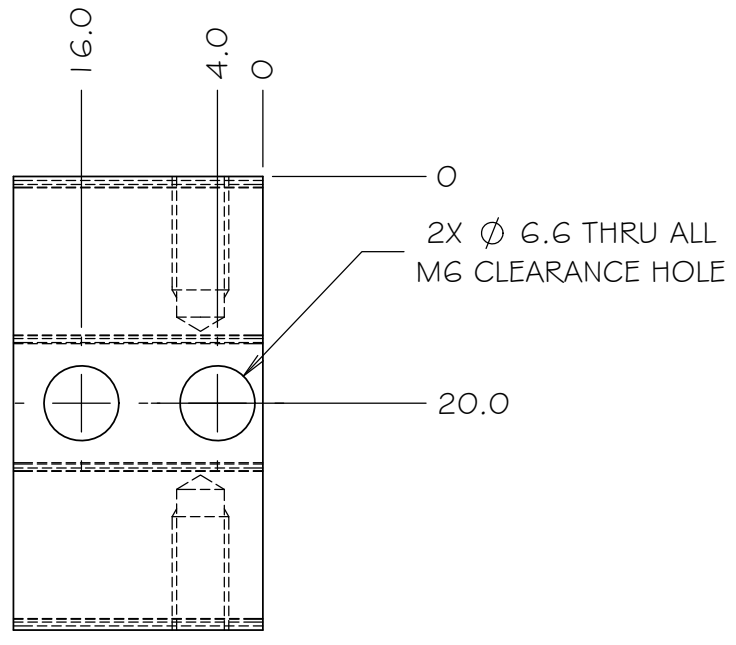

NOTES

1. MATERIAL: FREE MACHINING BRASS OR SIMILAR

UNLESS OTHERWISE NOTED DIMENSIONS ARE IN MILLIMETERS * TOLERANCES ARE AS FOLLOWS:
 X.X: ±0.10mm X.XX: ±0.01mm
 ANGLES: ±0.5° FINISH: 3 MICRONS (µm)
 BREAK ALL SHARP EDGES * CORNERS .25mm MAX

MATERIAL	FINISH
SEE NOTE 1	--

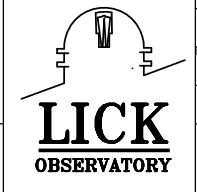

DRAWN C. RATLIFF		KECK I DEPLOYABLE TERTIARY MIRROR	
CHECKED J. WARD		TOOLING	
DESIGNED C. RATLIFF	4/26/16	TITLE V-BLOCK ADJUSTOR BASE	
ENGINEER C. RATLIFF	4/26/16	QUANTITY 2	REV A
SW DOCUMENT FILE 872-LM8213.SLDPRT		PROJECT CODE K1D3FD	DWG NO 872-LM8213
		NEXT ASSY 872-LM0000	