

REVISIONS				
REV	DATE	DRW'N	CHK'D	DESCRIPTION
A	15MAY17	GFC	--	INITIAL RELEASE

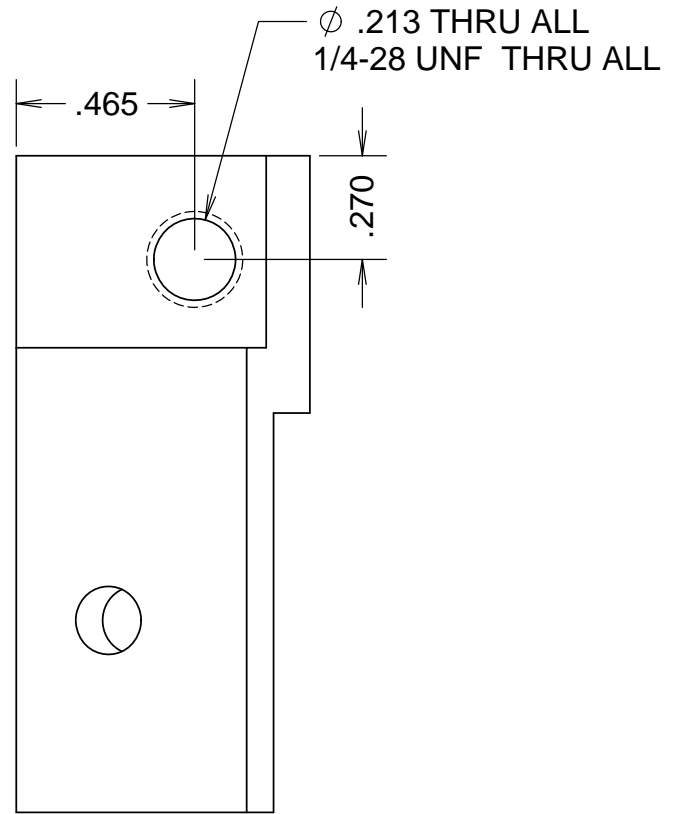
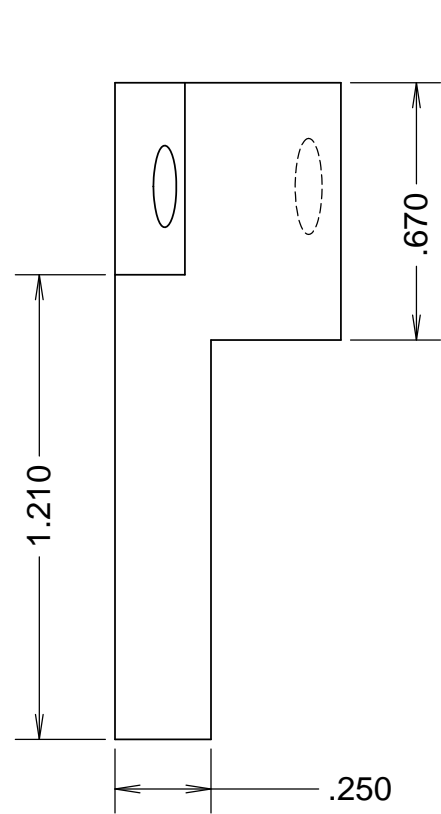
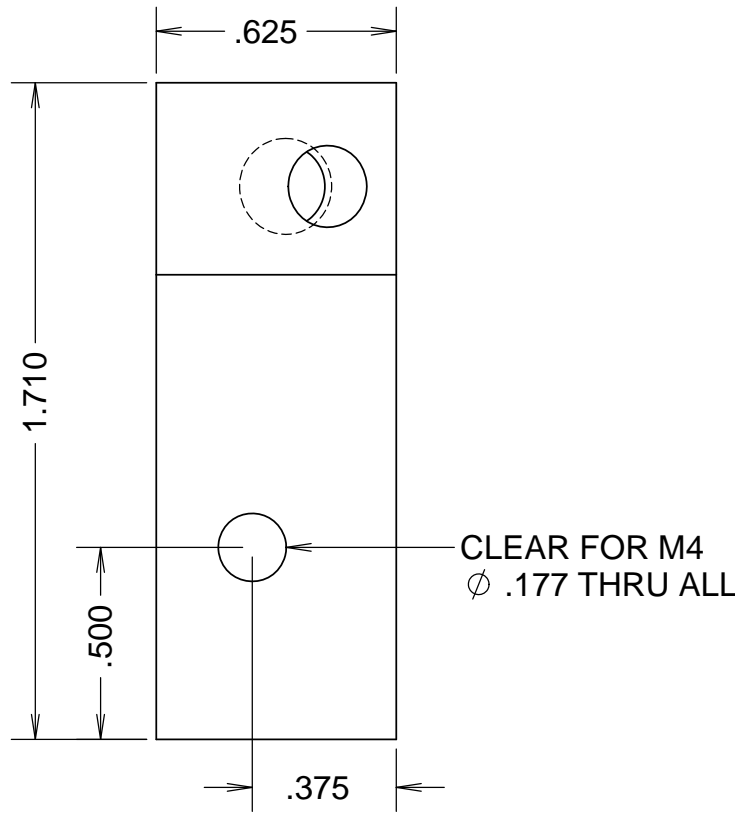
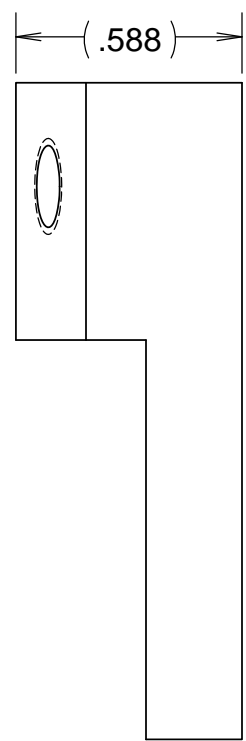
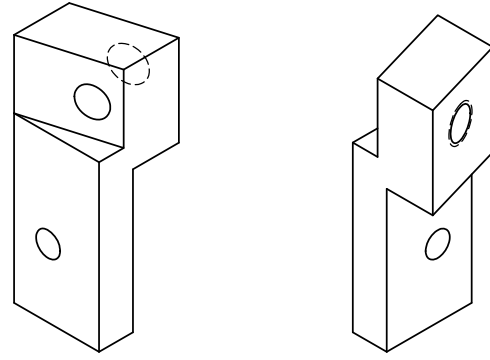
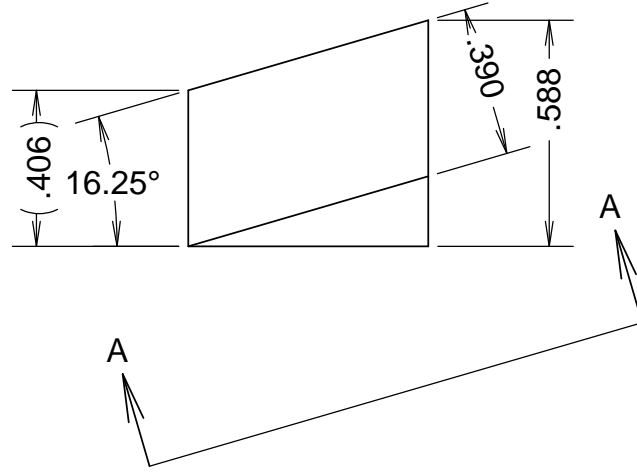

VIEW A-A

NOTES

- 1 CAD MODEL FILENAME, 872-LM4532 Groove Lock T4A
- 2 BREAK ACUTE EDGES
- 3 PAINT, AEROGLAZE Z306 FLAT BLACK PER MANUFACTURER'S SPECS

UNLESS OTHERWISE NOTED DIMENSIONS ARE IN INCHES & TOLERANCES ARE AS FOLLOWS

X.X: ±0.1000"	X.XX: ±0.0100"
X.XXX: ±0.0050"	X.XXXX: ±0.0001"
ANGLES: ±0.5° FINISH: 125 MICRO INCHES BREAK ALL SHARP EDGES & CORNERS .002" MAX	
MATERIAL 1018	FINISH 64/3

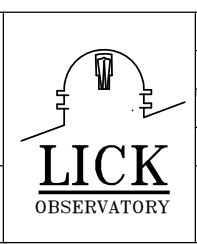

DRAWN CABAK	DATE --	PROJECT CODE K1D3FD	DWG NO 872-LM4700	TITLE GROOVE LOCK, TYPE 4A	REV A
CHECKED --	DESIGNED CABAK	PROJECT CODE 872-LM4700	DWG NO 872-LM4532	TITLE KECK 1 DEPLOYABLE TERTIARY MIRROR SWING ARM ASSEMBLY	REV 1/1
APPROVED CABAK	DATE --				