

REVISIONS				
REV	DATE	DRW'N	CHCK'D	DESCRIPTION
A	25AUG16	GFC	--	INITIAL RELEASE
B	11OCT16	GFC	JW/DM	DESIGN CHANGE

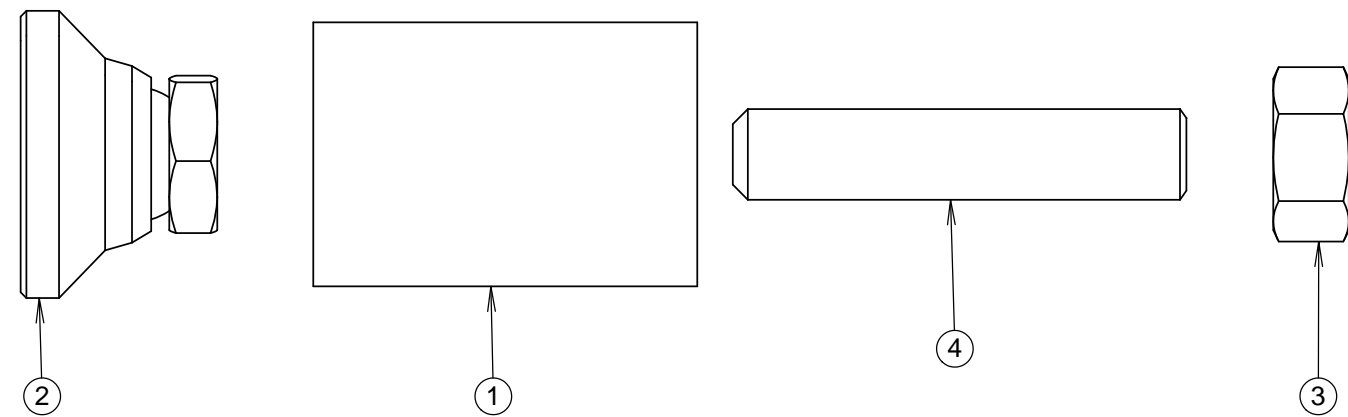
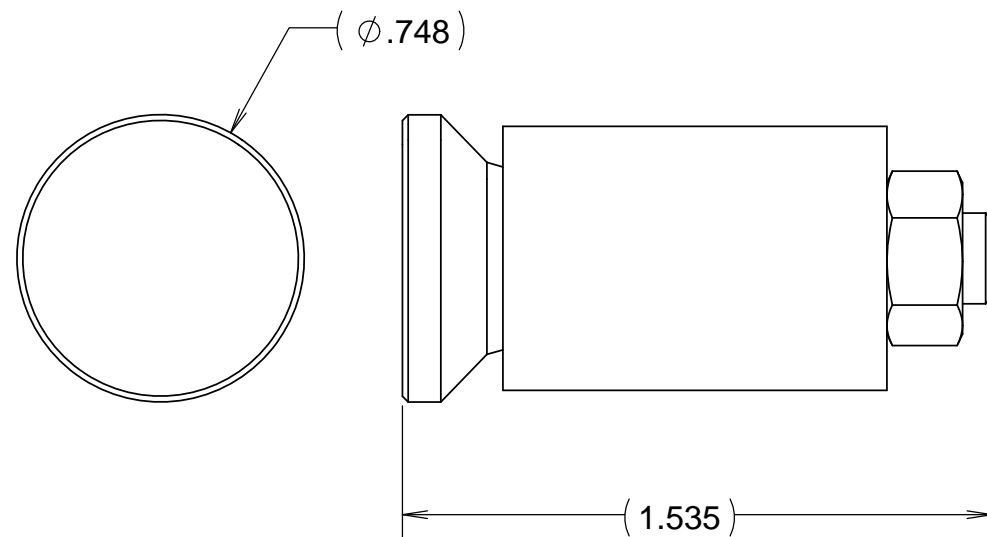

ITEM	QTY	P/N	DESCRIPTION
1	1	872-LM4525	LEVELING PAD SLEEVE
2	1	6120K31	SWIVEL MOUNT, M6 THREAD, MCMaster-CARR
3	1	H/W	HEX NUT, M6
4	1	HW	SET SCREW, FLAT, M6 X 30

NOTES

1 BROACH SWIVEL PAD (1) INTO SLEEVE

UNLESS OTHERWISE NOTED DIMENSIONS ARE IN INCHES & TOLERANCES ARE AS FOLLOWS
 X.X: ±0.1000" X.XX: ±0.0100"
 X.XXX: ±0.0050" X.XXXX: ±0.0001"
 ANGLES: ±0.5° FINISH: 125 MICRO INCHES
 BREAK ALL SHARP EDGES & CORNERS .002" MAX

MATERIAL	FINISH
PARTS LIST	NA



DRAWN	CABAK	--	KECK 1 DEPLOYABLE TERTIARY MIRROR SWING ARM
CHECKED	--	--	
DESIGNED	CABAK	--	LEVELING PAD ASSEMBLY
ENGINEER	CABAK	--	
SW DOCUMENT FILE	PROJECT CODE		DWG NO
872-LM4526 Level Pad Assy	K1D3FD		872-LM4526
	NEXT ASSY		
	872-LM4700		

B
1/1