

REVISIONS				
REV	DATE	DRWN	CHCK'D	DESCRIPTION
A	17OCT17	GFC	--	INITIAL RELEASE
B	30OCT17	GFC	DM	DIMENSION ADDED
C	16NOV17	GFC	--	HOLE CHANGE

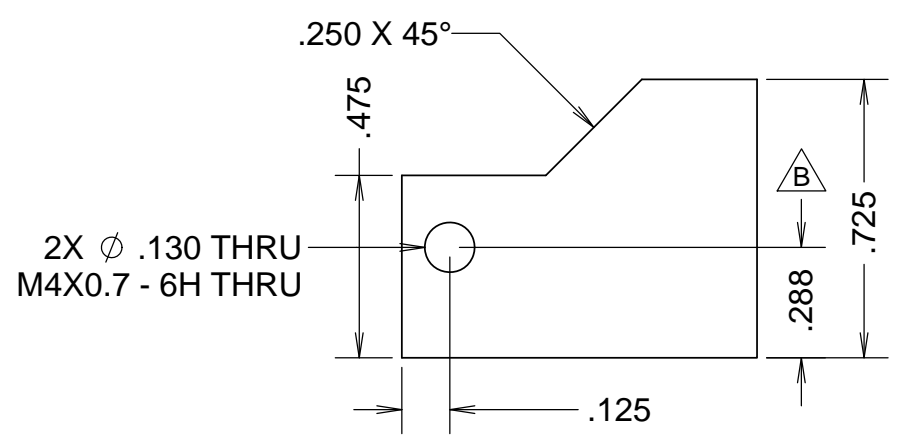
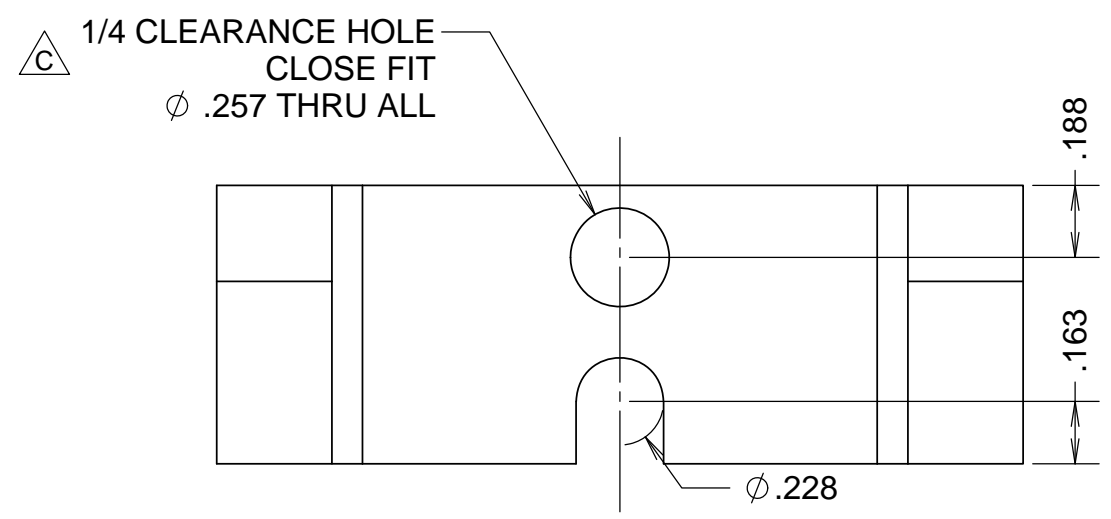
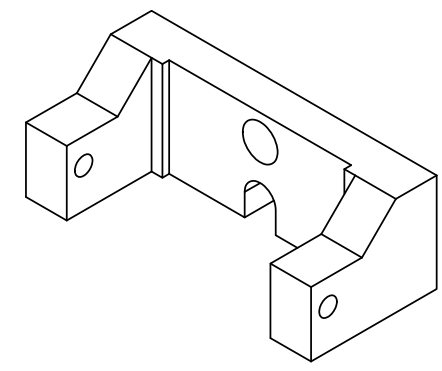
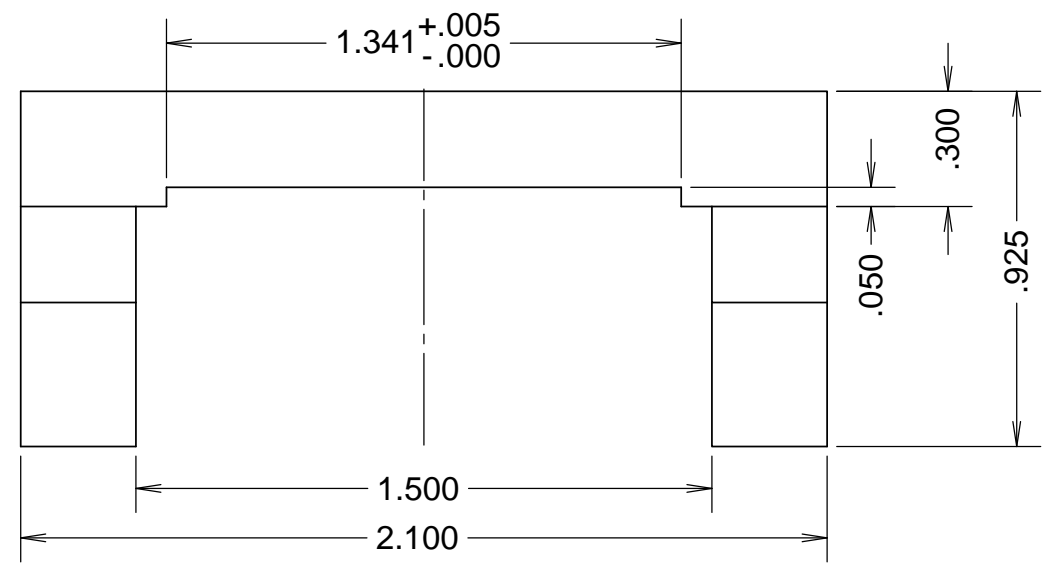

NOTES

1 CAB MODEL FILENAME, 872-LM4040 Collar Lock T2

UNLESS OTHERWISE NOTED DIMENSIONS ARE IN INCHES & TOLERANCES ARE AS FOLLOWS

X.X: $\pm 0.1000''$ X.XX: $\pm 0.0100''$
X.XXX: $\pm 0.0050''$ X.XXXX: $\pm 0.0001''$
ANGLES: $\pm 0.5^\circ$ FINISH: 125 MICRO INCHES
BREAK ALL SHARP EDGES & CORNERS .002" MAX

MATERIAL	FINISH
303/304 SST	64

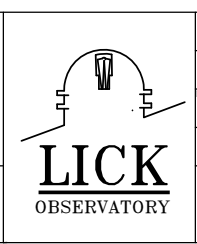

DRAWN	CABAK	--	KECK 1 DEPLOYABLE TERTIARY MIRROR
CHECKED	--	--	MIRROR ASSEMBLY
DESIGNED	CABAK	--	TITLE
APPROVED	CABAK	--	COLLAR LOCK, TYPE 2
SW DOCUMENT FILE	1	PROJECT CODE	K1D3FD
		DWG NO	872-LM4040
		NEXT ASSY	872-LM4200
			872-LM4040
			C 1/1