

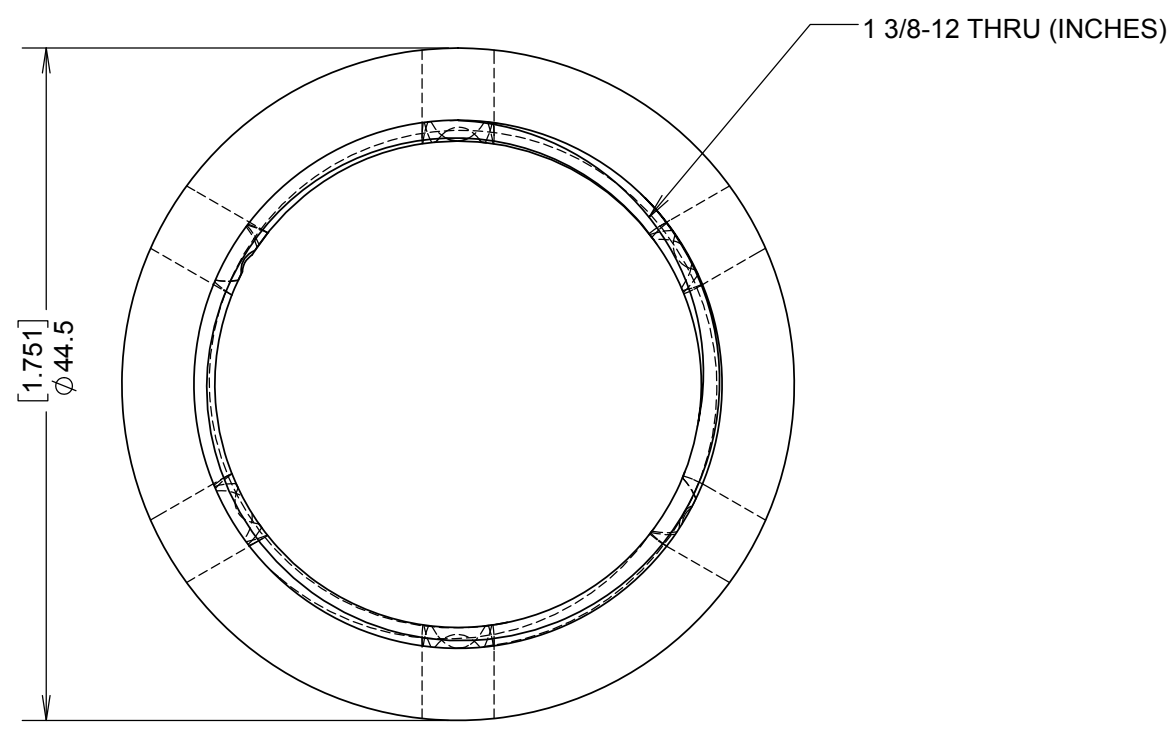

REVISIONS				
REV	DATE	DRWN	CHK'D	DESCRIPTION
A	2/3/17	CR		INITIAL RELEASE

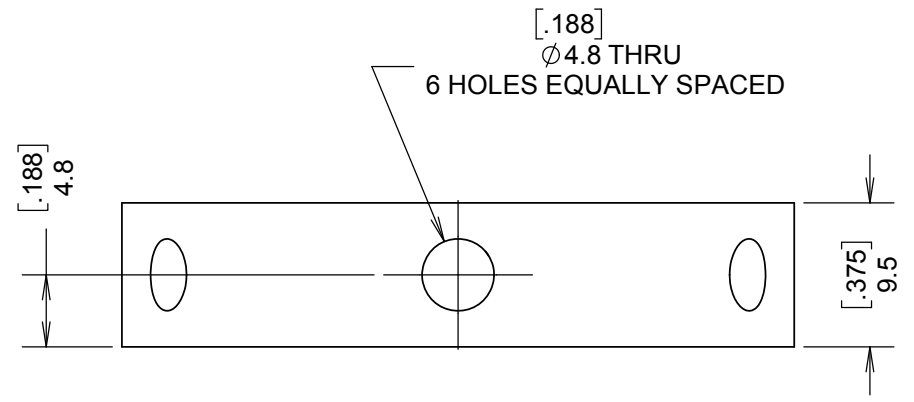

NOTES
 1. BRASS OR STAINLESS STEEL

UNLESS OTHERWISE NOTED DIMENSIONS ARE IN MILLIMETERS & TOLERANCES ARE AS FOLLOWS: X.X: ± 0.10 mm X.XX: ± 0.01 mm ANGLES: $\pm 0.5^\circ$ FINISH: 3 MICRONS (μm) BREAK ALL SHARP EDGES & CORNERS .25mm MAX			DRAWN RATLIFF	2/3/17	KECK 1 DEPLOYABLE TERTIARY MIRROR	
MATERIAL SEE NOTE 1			FINISH NA	CHECKED CABAK	2/3/17	STOW AND DEPLOY SYSTEM
			DESIGNED --	--	TITLE DIE SPRING LOCK NUT	
			ENGINEER --	--	PROJECT CODE --	DWG NO 872-LM2245
			SW DOCUMENT FILE 872-LM2245.SLDPRT	QUANTITY 4	NEXT ASSY NEXT ASSY	REV A 1/1