

REVISIONS				
REV	DATE	DRWN	CHK'D	DESCRIPTION
A	2/3/17	CR		INITIAL RELEASE

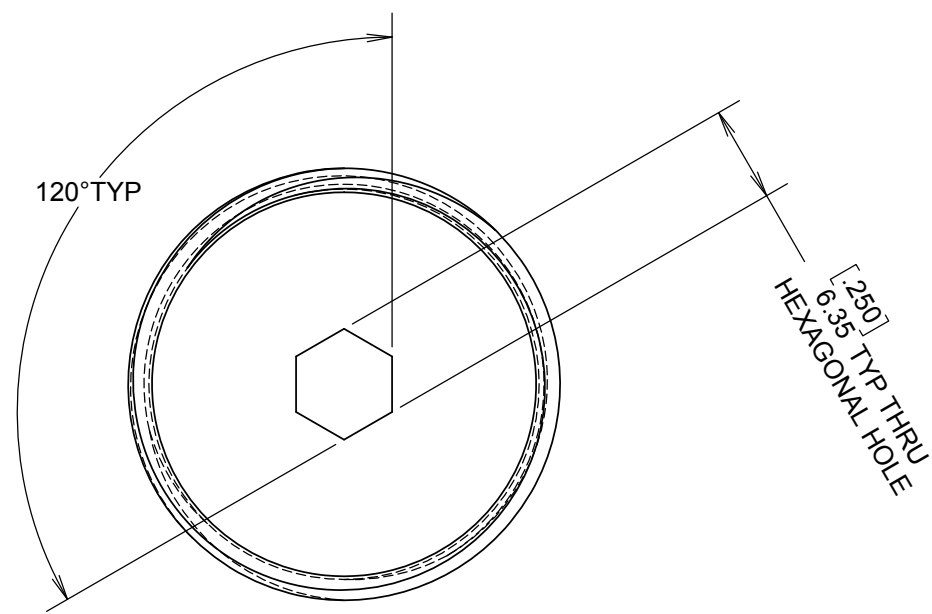

**NOTES**  
 1. STEEL THAT CAN BE TACK WELDED TO 872-LM2240

UNLESS OTHERWISE NOTED DIMENSIONS ARE IN MILLIMETERS & TOLERANCES ARE AS FOLLOWS:  
 X.X: ±0.10 mm X.XX: ±0.01 mm  
 ANGLES: ±0.5° FINISH: 3 MICRONS (µm)  
 BREAK ALL SHARP EDGES & CORNERS .25mm MAX

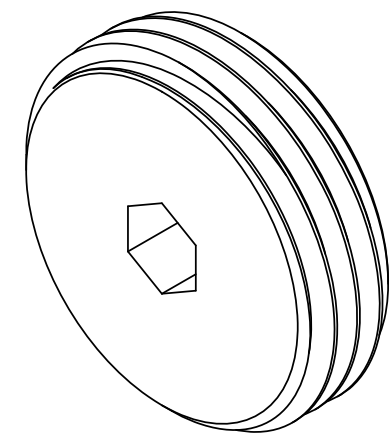
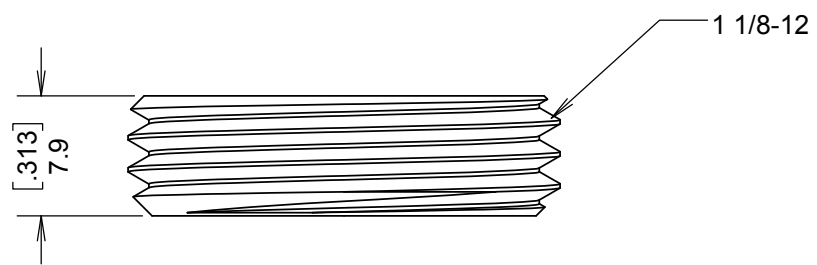
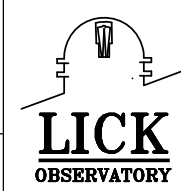

DRAWN <b>RATLIFF</b>	2/3/17	KECK 1 DEPLOYABLE TERTIARY MIRROR	
CHECKED <b>CABAK</b>	2/3/17	STOW AND DEPLOY SYSTEM	
DESIGNED --	--	TITLE SCREW CAP MODIFIED	
ENGINEER --	--	PROJECT CODE --	DWG NO <b>872-LM2244</b>
MATERIAL SEE NOTE 1	FINISH NA	SW DOCUMENT FILE 872-LM2244.SLDPRT	QUANTITY <b>4</b>
		NEXT ASSY 872-LM2242	REV <b>A</b> 1/1