

REV	DRWN	CHK'D	DATE	DESCRIPTION
N/A	GFC			CHECK PRINT - FOR REFERENCE ONLY

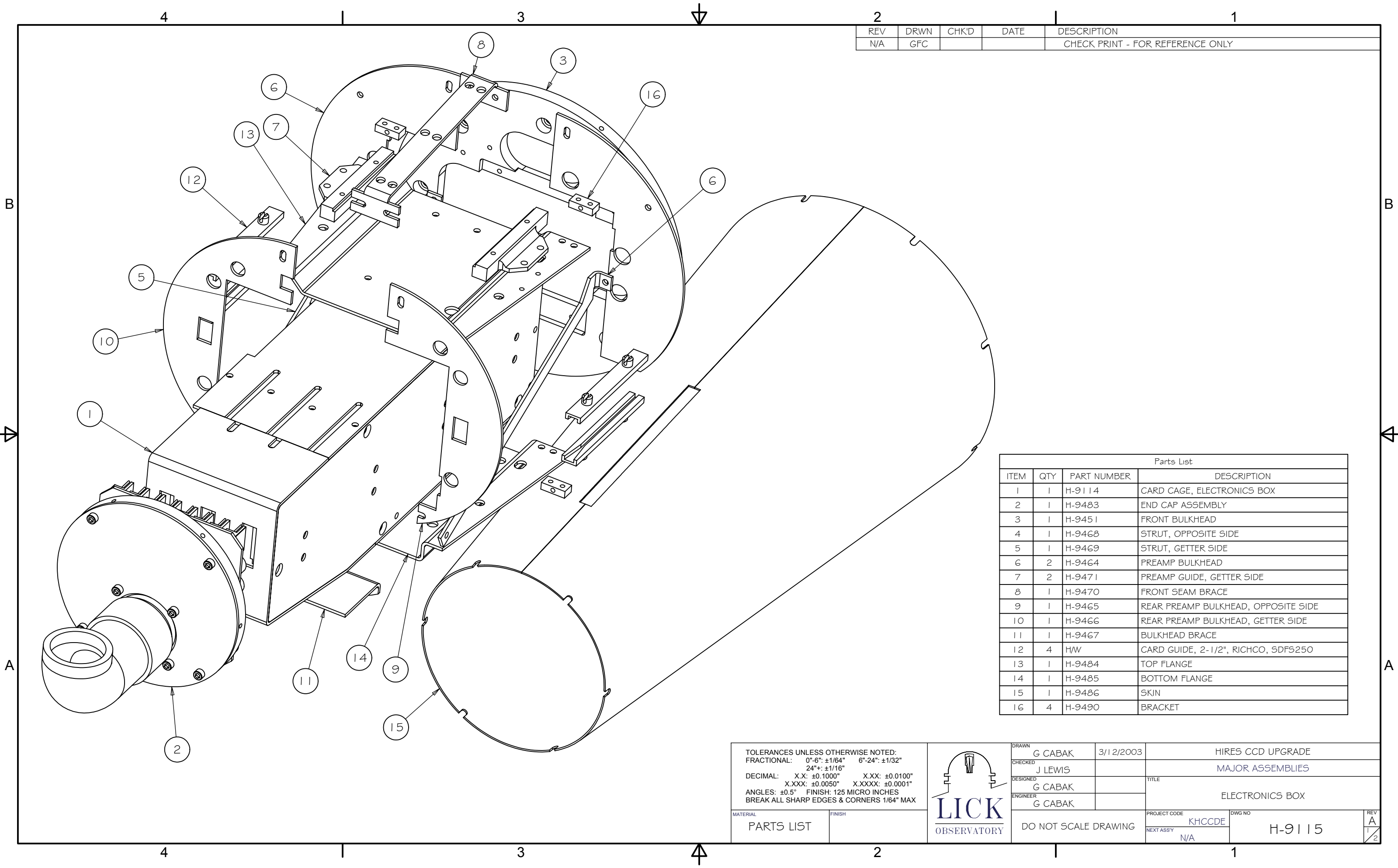

Parts List			
ITEM	QTY	PART NUMBER	DESCRIPTION
1	1	H-9114	CARD CAGE, ELECTRONICS BOX
2	1	H-9483	END CAP ASSEMBLY
3	1	H-9451	FRONT BULKHEAD
4	1	H-9468	STRUT, OPPOSITE SIDE
5	1	H-9469	STRUT, GETTER SIDE
6	2	H-9464	PREAMP BULKHEAD
7	2	H-9471	PREAMP GUIDE, GETTER SIDE
8	1	H-9470	FRONT SEAM BRACE
9	1	H-9465	REAR PREAMP BULKHEAD, OPPOSITE SIDE
10	1	H-9466	REAR PREAMP BULKHEAD, GETTER SIDE
11	1	H-9467	BULKHEAD BRACE
12	4	H/W	CARD GUIDE, 2-1/2", RICHCO, SDF5250
13	1	H-9484	TOP FLANGE
14	1	H-9485	BOTTOM FLANGE
15	1	H-9486	SKIN
16	4	H-9490	BRACKET

TOLERANCES UNLESS OTHERWISE NOTED:
 FRACTIONAL: 0"-6": ±1/64" 6"-24": ±1/32"
 24"+: ±1/16"
 DECIMAL: X.X: ±0.1000" X.XX: ±0.0100"
 X.XXX: ±0.0050" X.XXXX: ±0.0001"
 ANGLES: ±0.5° FINISH: 125 MICRO INCHES
 BREAK ALL SHARP EDGES & CORNERS 1/64" MAX

MATERIAL	FINISH
PARTS LIST	



DRAWN	G CABAK	3/12/2003	HIRES CCD UPGRADE
CHECKED	J LEWIS		MAJOR ASSEMBLIES
DESIGNED	G CABAK		TITLE
ENGINEER	G CABAK		ELECTRONICS BOX
PROJECT CODE	KHCCDE		DWG NO
NEXT ASSY	N/A		H-9115
REV	A		1/2

DO NOT SCALE DRAWING

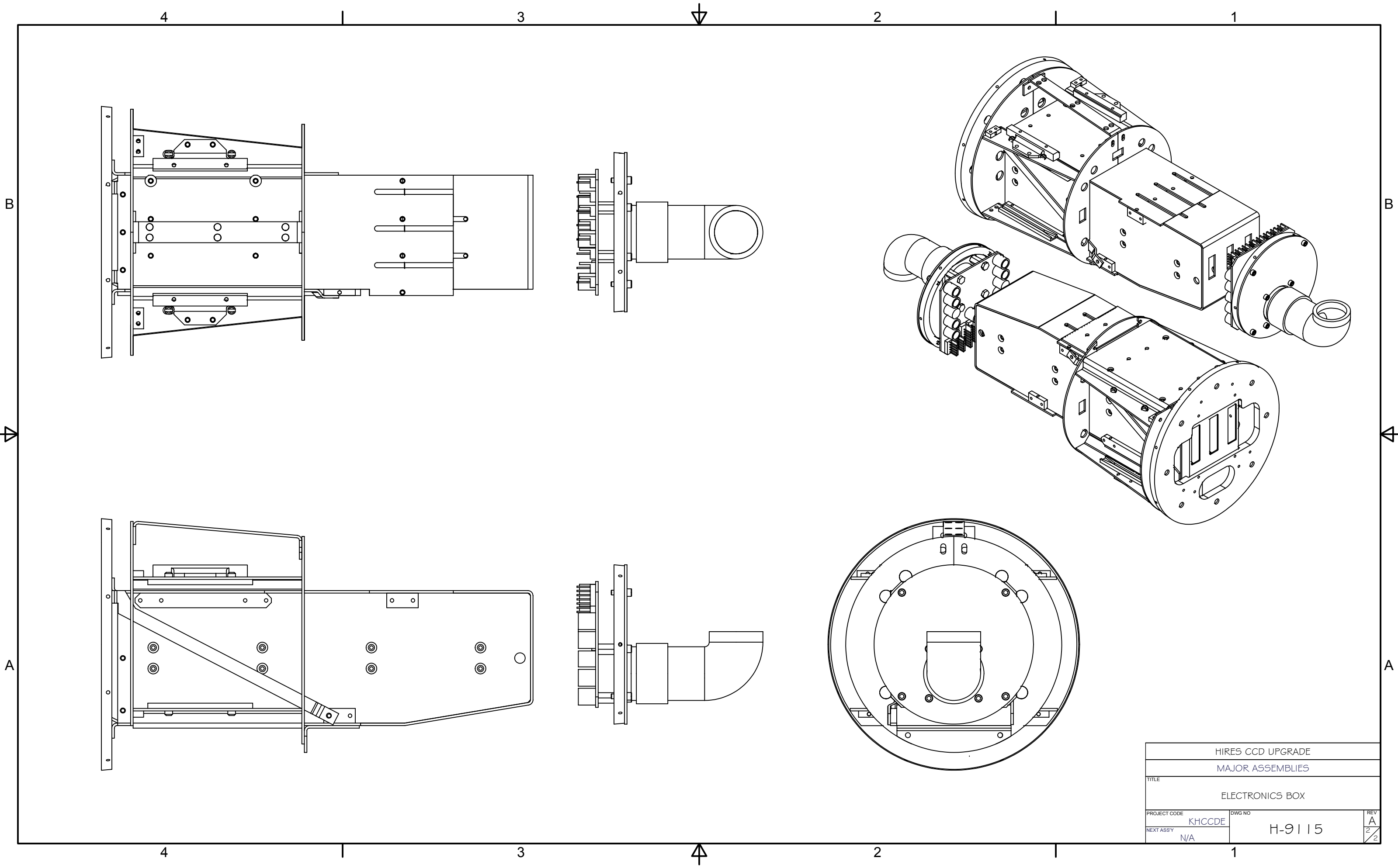

HIRES CCD UPGRADE		
MAJOR ASSEMBLIES		
TITLE ELECTRONICS BOX		
PROJECT CODE	DWG NO	REV
KHCCDE	H-9115	A
NEXT ASSY		2/2
N/A		