

4

3

2

1

REV	DRWN	CHK'D	DATE	DESCRIPTION
A	GFC	BA	11/14/03	INITIAL RELEASE

B

B

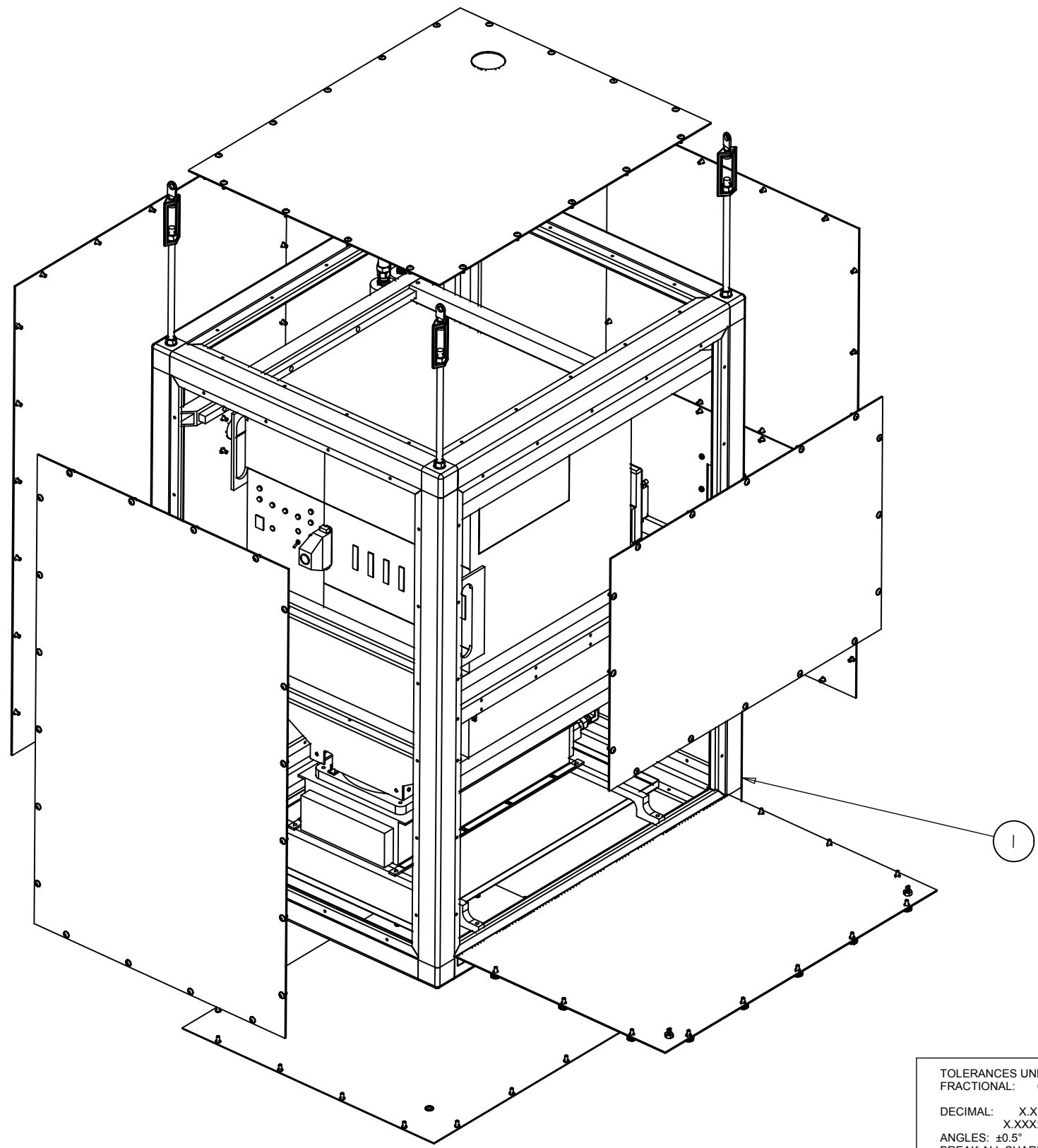

A

A

A

A

PARTS LIST			
ITEM	QTY	P/N	DESCRIPTION
1	1	H-9119	FOOTLOCKER MECHANICAL ASSEMBLY
4	1	EL-3411	CCD CONTROLLER
5	1	ELEC ASSY	FOOTLOCKER INTERFACE CHASSIS

TOLERANCES UNLESS OTHERWISE NOTED:
 FRACTIONAL: 0"-6": ±1/64" 6"-24": ±1/32"
 24"+: ±1/16"
 DECIMAL: X.X: ±0.1000" X.XX: ±0.0100"
 X.XXX: ±0.0050" X.XXXX: ±0.0001"
 ANGLES: ±0.5° FINISH: 125 MICRO INCHES
 BREAK ALL SHARP EDGES & CORNERS 1/64" MAX

MATERIAL	FINISH
PARTS LIST	

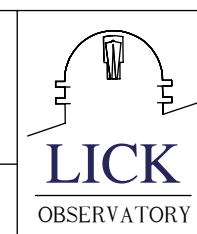

DRAWN	G CABAK	11/14/2003	HIRES CCD UPGRADE
CHECKED	B ALCOTT		MAJOR ASSEMBLIES
DESIGNED	G CABAK		TITLE
ENGINEER	G CABAK		FOOTLOCKER & ELECTRONICS
DO NOT SCALE DRAWING		PROJECT CODE	KHCCDE
		NEXT ASSY	N/A
		DWG NO	H-9126

REV	DESCRIPTION
A	1/2

4

3

2

1

A

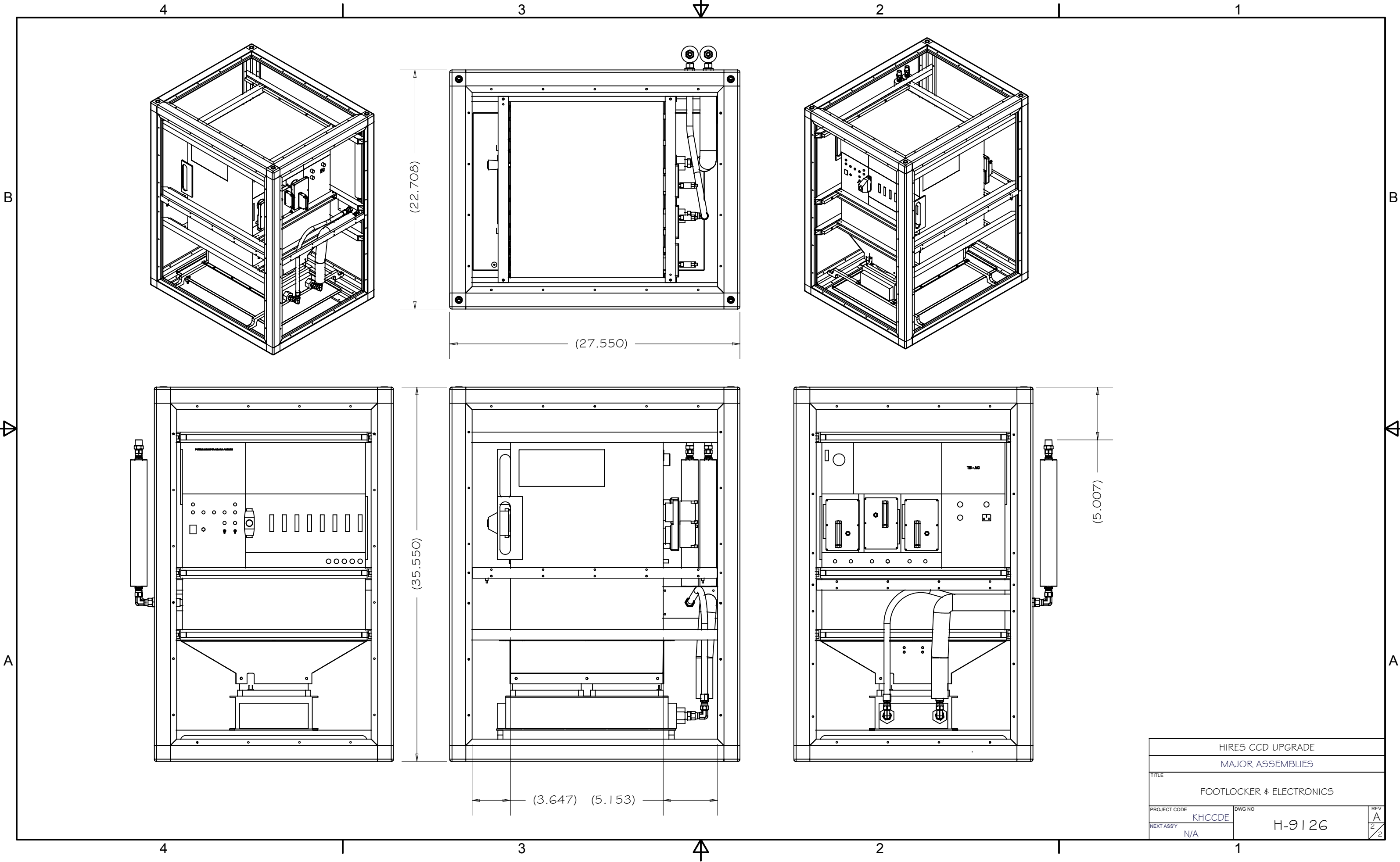

HIRES CCD UPGRADE			
MAJOR ASSEMBLIES			
TITLE			
FOOTLOCKER # ELECTRONICS			
PROJECT CODE	KHCCDE	DWG NO	REV
N/A		H-9126	A
			2/2