

REV	DRWN	CHK'D	DATE	DESCRIPTION
A	GFC	GFC	4/28/03	INITIAL RELEASE
B	GFC	JL/DK	5/1/03	ADDED ITEMS 17 & 18
C	GFC	DK	5/8/03	REMOVED ITEM 8; ADDED ITEMS 19 & 20

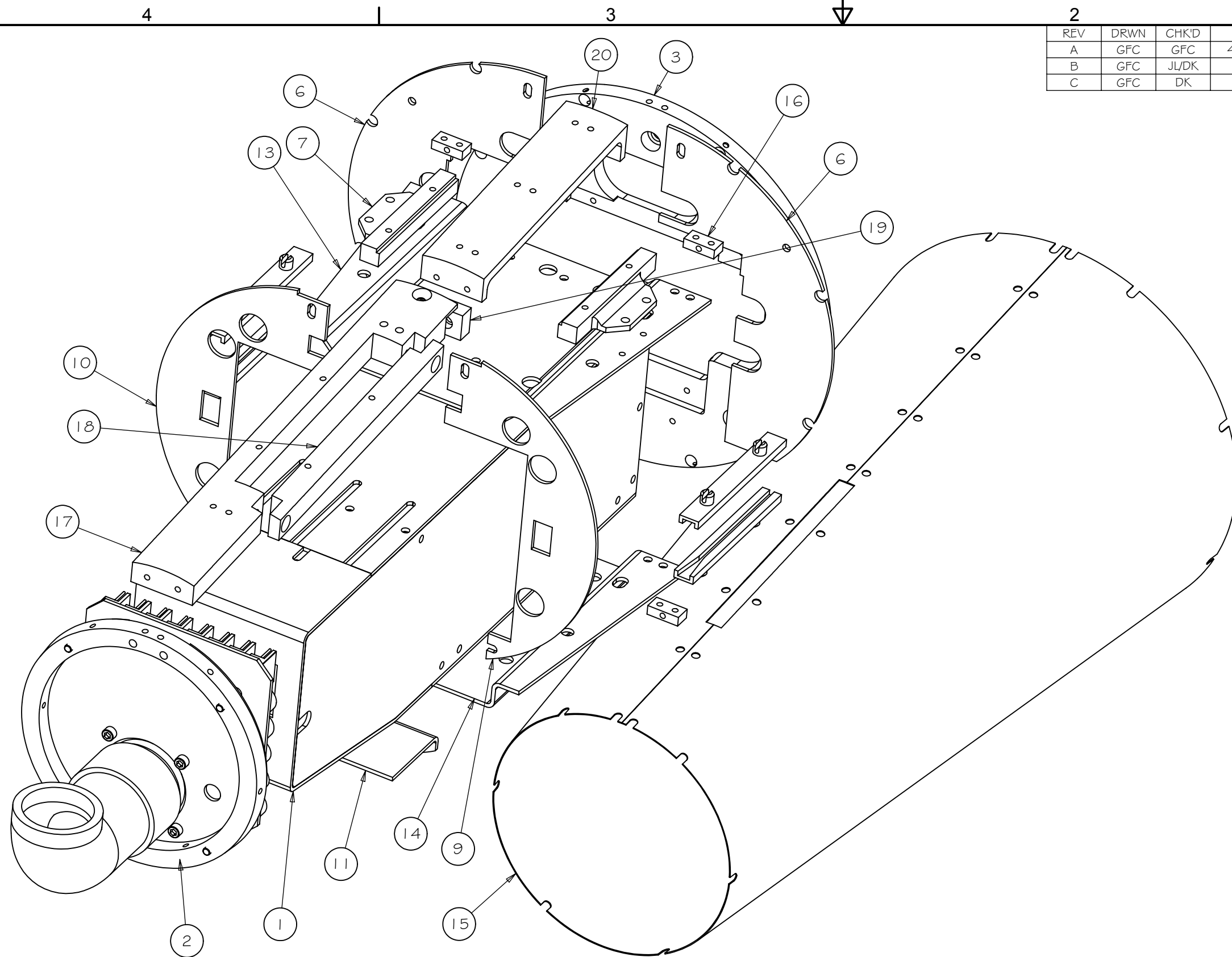

Parts List			
ITEM	QTY	PART NUM	DESCRIPTION
1	1	H-9114	CARD CAGE, ELECTRONICS BOX
2	1	H-9483	END CAP ASSEMBLY
3	1	H-9451	FRONT BULKHEAD
6	2	H-9464	PREAMP BULKHEAD
7	2	H-9471	PREAMP GUIDE
9	1	H-9465	REAR PREAMP BULKHEAD, OPPOSITE SIDE
10	1	H-9466	REAR PREAMP BULKHEAD, GETTER SIDE
11	1	H-9467	BULKHEAD BRACE
21	4	H/W	CARD GUIDE, 2-1/2", RICHCO, SDF5250
13	1	H-9484	TOP FLANGE
14	1	H-9485	BOTTOM FLANGE
15	1	H-9486	SKIN
16	4	H-9490	BRACKET
17	1	H-9496	BACK SEAM BRACE
18	1	H-9497	BACK SEAM BAR
19	1	H-9499	MOUNTING BLOCK
20	1	H-9953	PREAMP SEAM BRACE

TOLERANCES UNLESS OTHERWISE NOTED:  
 FRACTIONAL: 0"-6": ±1/64" 6"-24": ±1/32"  
 24"+: ±1/16"  
 DECIMAL: X.X: ±0.1000" X.XX: ±0.0100"  
 X.XXX: ±0.0050" X.XXXX: ±0.0001"  
 ANGLES: ±0.5° FINISH: 125 MICRO INCHES  
 BREAK ALL SHARP EDGES & CORNERS 1/64" MAX

MATERIAL	FINISH
PARTS LIST	



DRAWN G CABAK	3/12/2003	HIRES CCD UPGRADE	
CHECKED J LEWIS		MAJOR ASSEMBLIES	
DESIGNED G CABAK		ELECTRONICS BOX	
ENGINEER G CABAK		PROJECT CODE KHCCDE	DWG NO H-9115
DO NOT SCALE DRAWING		NEXT ASSY H-9122	REV C 1/2

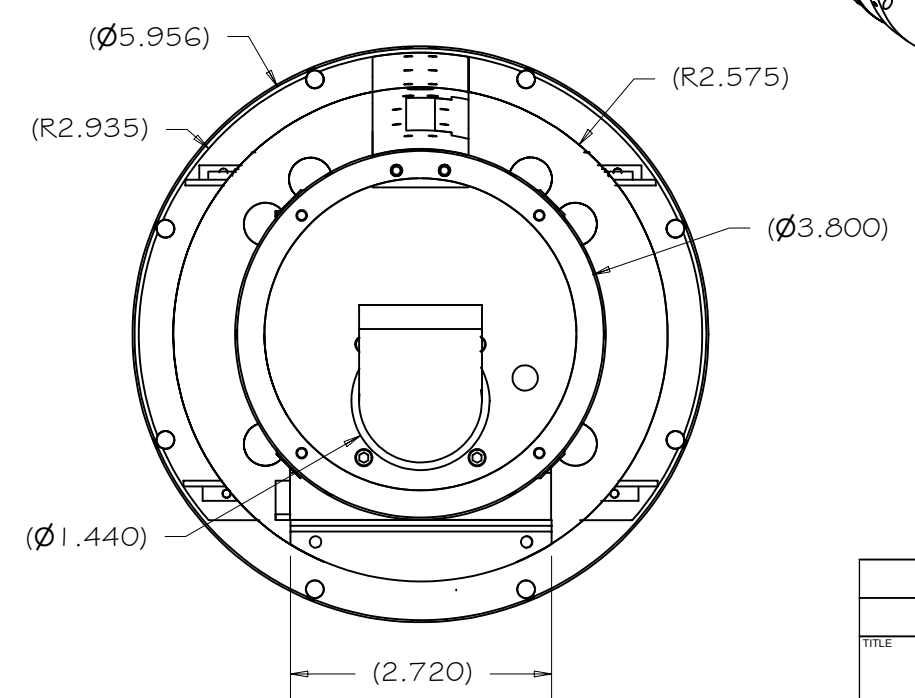
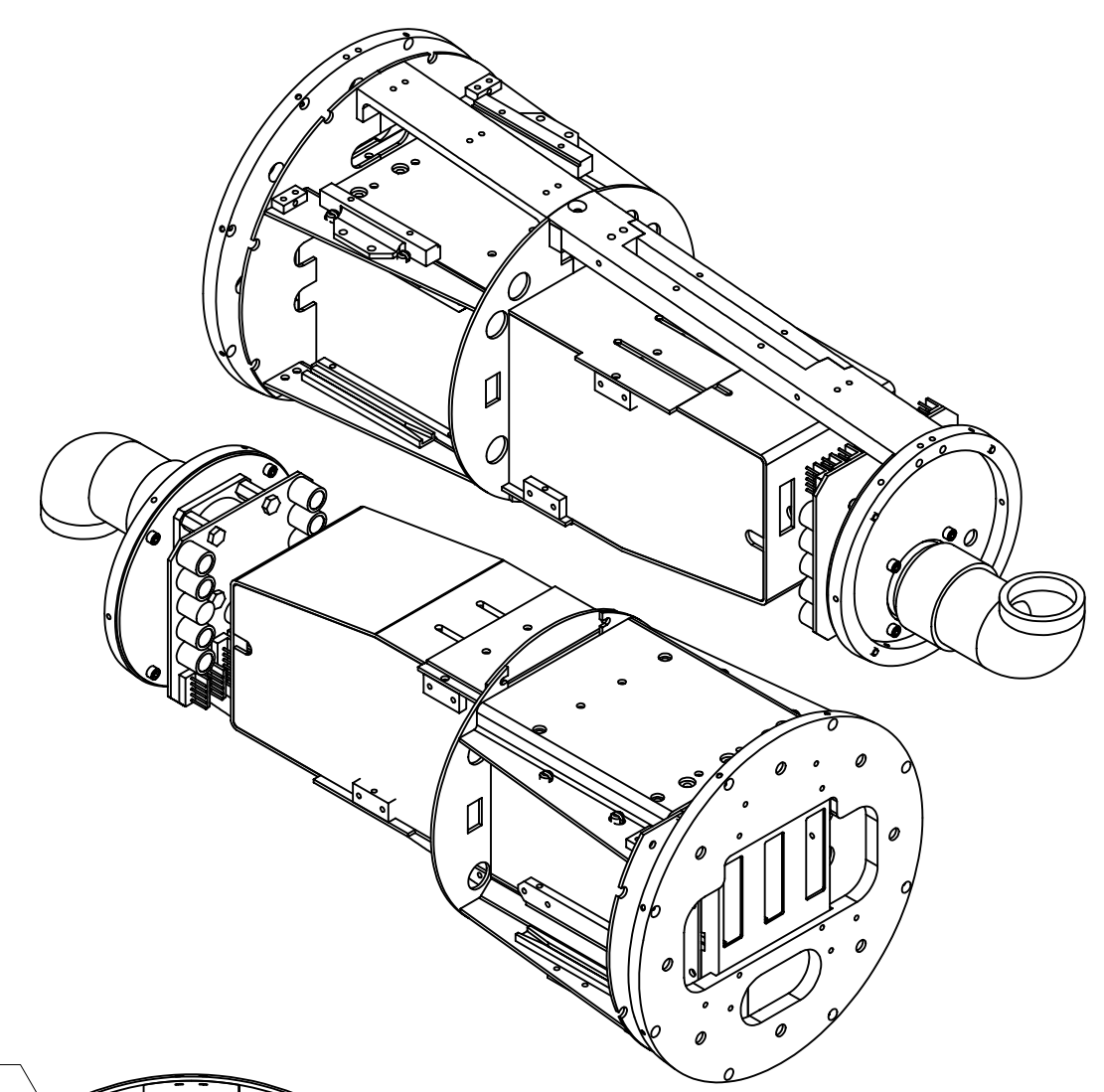
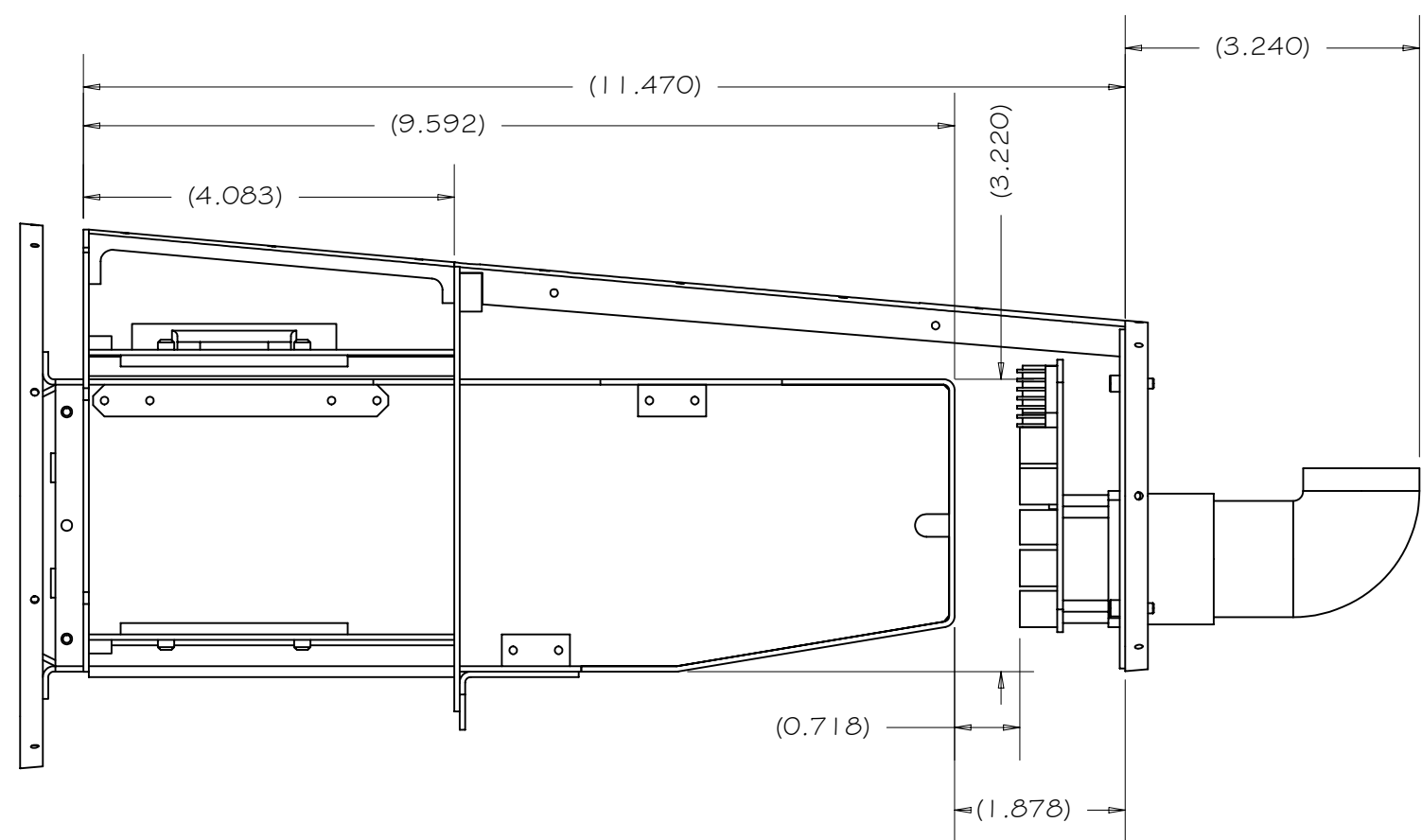
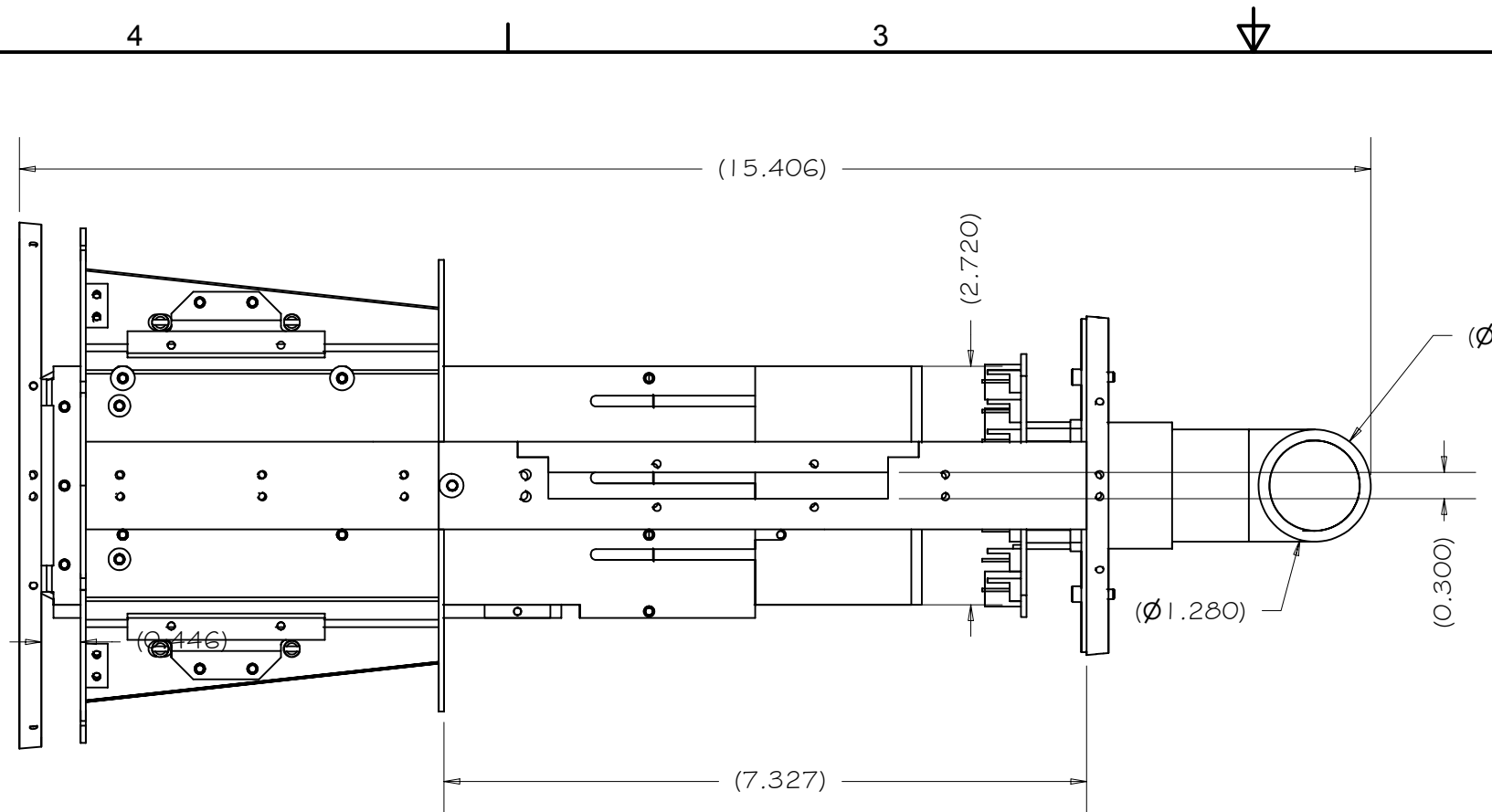

HIRES CCD UPGRADE			
MAJOR ASSEMBLIES			
TITLE ELECTRONICS BOX			
PROJECT CODE	KHCCDE	DWG NO	H-9115
NEXT ASSY	H-9122	REV	C
			2/2