

Temescal

SuperSource2™

PopTop Electron Beam Turret Source

Model STIH-270-2PT

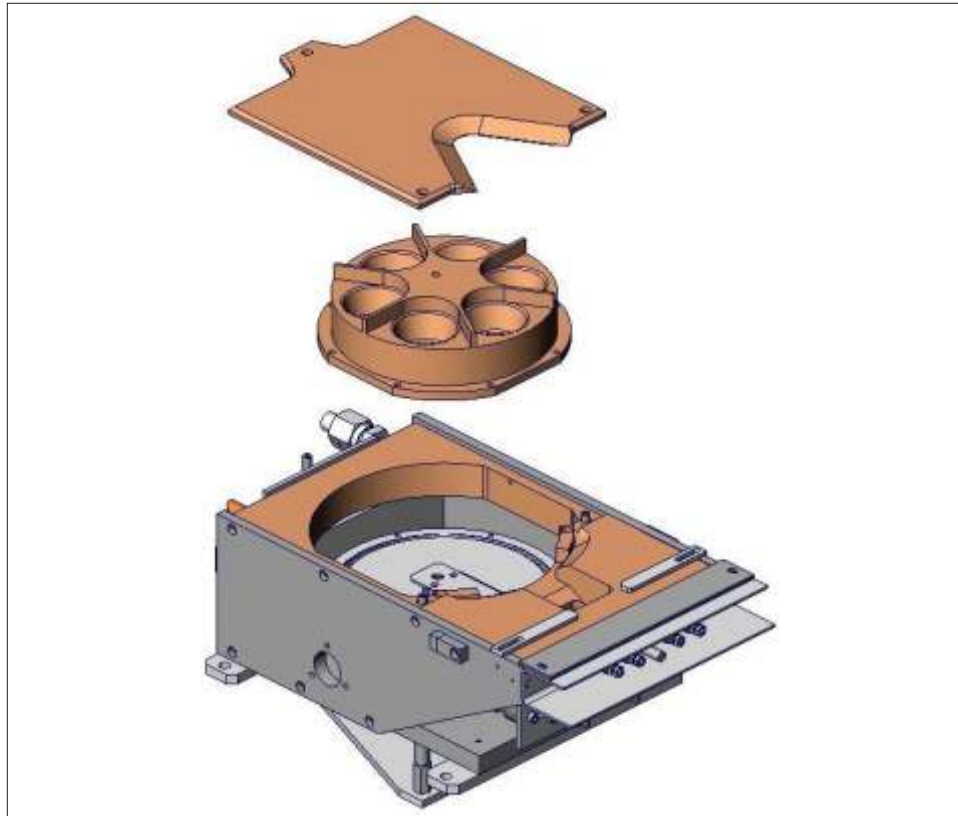

Temescal,
a division of BOC Edwards, Inc.
4569C Las Positas Road, Livermore, CA 94551; Tel. 925-371-4170; Fax. 925-449-4096

Revision History
0101-9004

REV.	VERSION/CHANGE DESCRIPTION	APPLICATION/REASON FOR CHANGE	DATE	APPV'D
-0	First released version of manual	Model STIH-270-2PT sources, beginning with SN 1	6/02	
-1	Second released version of manual	Corrections and updates	4/06	

Temescal,
A division of BOC Edwards, Inc.
4569C Las Positas Road
Livermore, CA 94551

©2002, 2006 by BOC Edwards, Inc.
All rights reserved

April, 2006

Contents

Section 1 Description and Specifications

1.1 Section Overview	1-1
1.2 Unpacking	1-2
1.3 Product Description	1-3
1.4 Specifications	1-7
1.5 Accessories	1-9

Section 2 Installation

2.1 Section Overview	2-1
2.2 Installation Requirements	2-2
2.3 Installation Procedure	2-5
2.4 Installing a Second Source	2-15

Section 3 Operation

3.1 Section Overview	3-1
3.2 Electron Beam Control	3-2
3.3 Initial Operation	3-6
3.4 Routine Inspection	3-9
3.5 Crucible Removal and Replacement	3-11

Section 4 Maintenance of High-Performance Emitter Assembly

4.1 Section Overview	4-1
4.2 Filament Replacement	4-2
4.3 Emitter Disassembly	4-4
4.4 Emitter Reassembly	4-5

Section 5 Source Disassembly

5.1 Section Overview	5-1
5.2 Source Removal and Disassembly	5-2
5.3 Disassembling the Bearing Housing Assembly	5-17
5.4 Disassembling the Drive Shaft Assembly	5-22

Section 6 Troubleshooting

6.1 Section Overview	6-1
6.2 Difficulties in Generating or Maintaining a Beam	6-2
6.3 Unsatisfactory Performance during Deposition	6-3
6.4 Beam-Position Problems	6-6
6.5 Other Malfunctions	6-8
6.6 Pop Top Feature not Functioning Correctly	6-10

Section 7 Engineering Drawing and Parts Lists

Illustrations

Section 1

- 1-1. STIH-270-2PT source viewed from the top 1-3
- 1-2. STIH-270-2PT source viewed from the front 1-4
- 1-3. Dimensions of STIH-270-2PT source - top, side, and front views 1-8

Section 2

- 2-1. Installation Details 2-6
- 2-2. Correct placement of high-voltage shielding 2-7
- 2-3. Typical installation of bottom-drive model (STIH-270-2PT) 2-8
- 2-4. Two methods of setting up a low-impedance ground for the vacuum system. 2-14
- 2-5. Magnetic shield mounted to water lines in two-gun installation 2-15
- 2-6. Magnetic shield mounted to debris shield in two-gun installation 2-16

Section 3

- 3-1. Correct mounting location for shunt bar(s). 3-3
- 3-2. Location of the internal and external pole piece extensions. 3-5
- 3-3. Removing the crucible cover. 3-12
- 3-4. Correct arrangement of sleeve on shaft of Allen driver 3-13
- 3-6. Removing the screws that secure the crucible to the crucible mounting flange 3-14
- 3-5. Socket-head screw correctly retained by sleeve on end of Allen driver. 3-14
- 3-7. Source with crucible cover removed and knurled thumbscrew in place in top of the crucible 3-15
- 3-8. Removing the crucible from the source. Note angle of withdrawal 3-16

Section 4

- 4-1. Front view of high-performance emitter assembly 4-7
- 4-2. High-performance emitter viewed from rear 4-7
- 4-3. Exploded view of high-performance emitter 4-8

Section 5

- 5-1. Removing the crucible cover 5-4
- 5-2. Detail of the sleeve on the Allen driver 5-5
- 5-3. Socket-head screw correctly retained by the sleeve on the end of the Allen driver 5-5

- 5-4. Removing the screws that secure the crucible to the crucible mounting flange 5-6
- 5-5. Removing the crucible from the source. Note angle of withdrawal 5-7
- 5-6. Removing the emitter assembly 5-8
- 5-8. Removing the screws that secure the coil housing to the pole pieces 5-9
- 5-7. Uncoupling the water-crossover tube 5-9
- 5-9. Removing the coil housing. 5-10
- 5-10. Removing the screws that secure the LH pole piece to the base plate 5-10
- 5-11. Correct technique for detaching pole pieces from magnet and base plate. 5-11
- 5-12. Removing the water baffle 5-12
- 5-13. Detaching the pivot plate shaft from the base plate 5-13
- 5-14. Removing the screws that secure the bearing housing assembly to the crucible mounting flange. 5-14
- 5-15. Parts layout, STIH-270-2PT source, with emitter, bearing housing assembly, and drive assembly still intact 5-15
- 5-16. Removing the retaining ring 5-17
- 5-17. Layout of the parts of the bearing housing assembly, in order of reassembly 5-17
- 5-18. Allen driver inserted through hole in the bearing housing 5-18
- 5-19. Removing the retaining ring that secures the outer crucible drive bearing in the bearing housing 5-22
- 5-20. Removing the retaining ring that retains the drive shaft 5-22
- 5-21. The parts of the drive shaft assembly laid out in order of reassembly 5-24

Section 6

- 6-1. Correct and incorrect beam-spot positions with 0 A longitudinal deflection current applied. 6-5

Section 7

- 7-1. Source assembly, STIH-270-2CKB, pop-up type. Side views 7-2
- 7-2. Source assembly, STIH-270-2CKB, pop-up type. Top and bottom views 7-3

SUMMARY OF TERMS AND CONDITIONS OF SALE

MECHANICAL WARRANTY: For a period of twelve (12) months from the date of original shipment to Purchaser thereof, the apparatus and each part or component manufactured by Temescal, a division of The BOC Group, Inc., hereinafter known as "Seller," is warranted to be free from functional defects in materials and workmanship. The foregoing warranty is subject to the condition that the apparatus, part, or component be properly operated under conditions of normal use, and that regular periodic maintenance and service be performed, or replacements made, in accordance with instructions provided by Seller. The foregoing warranty shall not apply to any apparatus, part, or component that has been repaired other than by Seller or an authorized representative of Seller, or in accordance with written instructions provided by Seller; that has been altered by anyone other than Seller; or that has been subject to improper installation or abuse, misuse, negligence, accident, or corrosion.

Purchaser's sole and exclusive remedy under the above warranty is limited to, at Seller's option, repair or replacement of defective parts or components, or return to Purchaser of the price of the apparatus. Any such obligation on Seller's part is subject to the following requirements: (x) the defect must be promptly reported to Seller; (y) if so advised by Seller, Purchaser must return the part or component with a statement of the observed deficiency not later than seven (7) days after the expiration date of the warranty to the address designated by Seller, during normal business hours, transportation charges prepaid; and (z) upon examination by Seller, the part or component must be found not to comply with the above warranty. Return trip transportation charges for the part or component shall be paid by Purchaser. In the event that Seller elects to refund the purchase price, the apparatus shall be the property of Seller and shall be promptly shipped to Seller at Seller's expense. This mechanical warranty shall be void and the apparatus shall be deemed to be purchased AS IS in the event that the entire purchase price has not been paid within thirty (30) days of original shipment of the apparatus.

THERE ARE NO EXPRESS OR IMPLIED WARRANTIES THAT EXTEND BEYOND THE WARRANTY HEREINABOVE SET FORTH. THERE IS NO WARRANTY OF MERCHANTABILITY OR FITNESS FOR A PARTICULAR PURPOSE WITH RESPECT TO THE APPARATUS OR ANY PART OR COMPONENT THEREOF, AND NO WARRANTY SHALL BE IMPLIED BY LAW.

Items not of Seller's manufacture but resold by Seller are the products of other manufacturers and their warranty, if any, shall apply. THERE ARE NO WARRANTIES OF ANY KIND ON PRODUCTS OF OTHER MANUFACTURERS RESOLD BY TEMESCAL, EXCEPT THE WARRANTY OF TITLE, AND NO WARRANTIES SHALL BE IMPLIED BY LAW. THERE IS NO EXPRESS OR IMPLIED WARRANTY OF MERCHANTABILITY OR OF FITNESS FOR A PARTICULAR PURPOSE WITH RESPECT TO PRODUCTS OF OTHER MANUFACTURERS.

PERFORMANCE WARRANTY: Seller warrants that the apparatus will comply with the specifications set forth in the purchase order. All specifications are subject to the corrections and tolerances allowed by the NEC. If the purchase order expressly provides for factory testing to verify compliance with the specifications, Purchaser shall be entitled to witness the testing and the results of the testing. Upon demonstration of compliance with the specifications by factory testing, Seller's liability for failure to comply with the specifications shall terminate. In the event that the purchase order does not describe a comprehensive test program for demonstration of compliance with the specifications, Seller's test program (which may incorporate extrapolation of data or test results based upon similarity of criteria established by Seller) shall be used for such purpose.

If the purchase order does not expressly provide for factory testing, compliance with the specifications shall be demonstrated by field testing which shall be conducted by Purchaser at Purchaser's expense. Seller shall have the right to: (a) witness the field testing and to verify the results of such field testing; (b)

have free access to all data compiled by Purchaser in connection with any field test; and (c) conduct its own field test at its own expense during any fourteen-day (14-day) consecutive period which may be mutually agreed upon by Seller and Purchaser; provided, however, that Seller shall have the right to field test within six (6) months of receipt from Purchaser of any notice of failure to comply with the specifications. If compliance with the specifications is to be demonstrated by field testing, Purchaser shall conduct and complete all field testing within sixty (60) days of the original shipment of the apparatus and shall promptly notify Seller of any failure to comply with the specifications. Seller shall not be liable for any failure to comply with the specifications demonstrated by field testing unless it receives notice thereof within sixty-seven (67) days of the date of original shipment of the apparatus.

In the event that factory testing or field testing does not demonstrate compliance with the specifications, Purchaser's sole and exclusive remedy under the above warranty is limited to, at Seller's option, repair or replacement of defective parts or components or return to Purchaser of the purchase price of the apparatus. In the event that Seller elects to refund the purchase price, the apparatus shall be the property of Seller.

Any obligations on Seller's part under this performance warranty are subject to the following requirements: (x) the nature of the failure of the apparatus to comply with the specifications must be promptly reported to Seller in writing; (y) if the apparatus has been delivered and field tested, Purchaser must return the apparatus or any part or component to Seller upon its request, not later than sixty-seven (67) days after initial shipment to Purchaser, to the address designated by Seller, during normal business hours, transportation charges prepaid; and (z) upon examination and testing by Seller, the apparatus must be found not to comply with the specifications. Return trip transportation charges for the apparatus or any part or component shall be paid by Purchaser. This performance warranty shall be void and the apparatus shall be deemed to be purchased AS IS in the event that the entire purchase price has not been paid within thirty (30) days of original shipment of the apparatus.

THERE ARE NO EXPRESS OR IMPLIED WARRANTIES THAT EXTEND BEYOND THE WARRANTY HEREINABOVE SET FORTH. THERE IS NO WARRANTY OF MERCHANTABILITY OR FITNESS FOR A PARTICULAR PURPOSE WITH RESPECT TO THE APPARATUS OR ANY PART OR COMPONENT THEREOF, AND NO WARRANTY SHALL BE IMPLIED BY LAW.

DISCLAIMER OF LIABILITY: IN NO EVENT SHALL SELLER BE LIABLE FOR DIRECT, INDIRECT, SPECIAL, INCIDENTAL, OR CONSEQUENTIAL DAMAGES ARISING FROM ANY SOURCE such as, but not limited to, the manufacture, use, delivery (including late delivery), or transportation of any apparatus, part, or component sold to Purchaser, whether such damages are caused by Seller's negligence or otherwise. Without limiting the generality of the foregoing sentence, Seller shall not be liable for: the cost of capital; the cost of substitute apparatus, services, repairs, components, or parts; loss of profit or revenue; the cost of power, whether purchased or produced by the consumer thereof; loss of use of the apparatus or any part thereof, or of any other property owned by Purchaser; claims or costs of Purchaser's customers; injury to persons, or death; or damages to any property. In the event that any limited warranty or disclaimer of liability is found to be unlawful or inapplicable, or to have failed of its essential purpose, Seller's liability shall be limited to the amount paid by Purchaser for the apparatus.

SAFETY INSTRUCTIONS FOR OPERATING AND SERVICE PERSONNEL

Operators and service personnel should always wear safety glasses. Operators shall not enter areas intended for service access only. Only experienced service personnel should enter such areas, and only after taking the preliminary precautions described in paragraphs 1 through 6 below.

DANGER

Potentially lethal voltages may exist within this system, even with the main power switched off. Service should only be attempted by qualified personnel. Failure to observe all safety precautions can result in personal injury.

Observe the precautions described below when servicing this system, especially when servicing components where high voltages might be present.

- 1 Before servicing or operating this equipment, read all the component manuals supplied with the system, paying special attention to safety instructions.
- 2 Post HIGH VOLTAGE WARNING signs in conspicuous locations within the service area.
- 3 Remove rings, watches, bracelets, and any other metal jewelry before working around high voltage.
- 4 DO NOT WORK ALONE!
- 5 Be sure that all equipment is connected to a power receptacle having the correct polarity and grounding, as prescribed by the local electrical codes. Refer to the power supply portion of the documentation to determine the proper electrical ground for high-voltage components.
- 6 Before servicing any high-voltage component, switch off the electrical power at the component's main power switch. This switch should have a lockout feature. Lock the power off and keep the key with you while you are working on the equipment.
- 7 Certain electrical parts (e.g., electrolytic capacitors) hold a lethal voltage even after the power is switched off. Before entering any service area, use a grounding hook to short out such parts. Be sure that these parts are discharged before starting any repairs.
- 8 DO NOT touch high-voltage leads unless power is off and a grounding hook is connected to the parts to be serviced.
- 9 The high-voltage components of the system should be equipped with electrical interlocks to protect personnel from injury. DO NOT ATTEMPT TO DEFEAT, OVERRIDE, OR BYPASS THESE PROTECTIVE DEVICES!
- 10 Never leave loose ends on high-voltage connections.
- 11 Observe the following warning if the system employs Radio Frequency (RF) power.

DANGER

RF radiation-even at modest power levels-can cause serious injury. If any of the RF components (e.g., the RF power supply, the RF matching network, or the RF electrodes or shielding inside the product chamber) are moved or changed in any way, the RF energy may be radiated outside the equipment. Monitor the equipment to assure that external RF radiation is below the levels prescribed by any and all applicable safety codes.

Special Amendment for United Kingdom Users

All Electrical Power Sources: Safety Precautions

Only authorized personnel should be permitted to carry out work on this system.

Prior to any servicing, grounding hooks should be used to short out all high-voltage parts and conductors in both the vacuum system and the high-voltage power supply. Screens protecting extra-high-voltage conductors should be removed only if appropriate action has been taken to ensure that extra-high-voltage conductors are dead and cannot be re-energized inadvertently.

In addition, all personnel should be aware of:

- 1 the Electricity (Factories Act) Special Regulations (1908 and 1944), in particular, Regulations 18(d) and 28 of the 1980 Regulations, as amended; and
- 2 the employer's responsibility to set up suitable systems to safeguard the health and safety of employees, according to the Health & Safety at Work etc. Act (1974).

USER RESPONSIBILITY

This equipment will perform in accordance with the instructions and information contained in the user's manual and its referenced documents when such equipment is installed, operated, and maintained in compliance with such instructions. The equipment must be checked periodically. Defective equipment shall not be used. Parts that are broken, missing, plainly worn, distorted, or contaminated, shall be replaced immediately. Should such repair or replacement become necessary, a telephonic or written request for service should be made to Temescal.

The equipment, or any of its parts, shall not be altered without the prior written approval of Temescal. The user and/or purchaser of this equipment shall have the sole responsibility for any malfunction which results from improper use, faulty maintenance, damage, improper repair, or alteration by any party other than Temescal.

HEALTH HAZARD

The condensates deposited on the tank walls of a vacuum system are generally in the form of extremely fine particles. The nature, as well as the form, of the materials pose the following potential health hazards:

- a) Inhaling fine particles (powder) may cause damage to the lungs. To help prevent this, wear a protective respirator mask with fine filter that has been approved by the National Institute for Occupational Safety and Health (NIOSH) and the federal Mine Safety and Health Administration (MSHA).
- b) Some substances are toxic and inhaling them should be avoided. Take steps to ascertain whether or not the material being deposited is a known toxic substance. Refer to the Material Safety Data Sheet(s) covering the evaporant(s) in question.
- c) Certain powders (titanium, for instance) can cause flash fires when exposed to oxygen or other oxidizers. Therefore, when opening the chamber door after a deposition cycle, exercise extreme caution and allow time for the coating surface to oxidize. Breakage of some of the more reactive condensates may be hazardous, even when the above precautions are observed. In this situation, fire-protective clothing should be worn.

SECTION 1

DESCRIPTION AND SPECIFICATIONS

1.1 SECTION OVERVIEW

This section provides a general description of the STIH-270-2PT source, detailed specifications for the product, and information about the available accessories. Section 1.2 describes the items that should be found in the shipping container, both for guns shipped fully assembled and for guns shipped as a base unit plus components. Section 1.3 provides a general product description, along with information on ordering additional crucibles for this convertible source. Section 1.4 contains the gun's specifications, including detailed dimensioned drawings, and section 1.5 provides information about the accessories that are available from Temescal to support the product.

1.2 UNPACKING

Remove the source from its shipping container. While unpacking, check the components in the container against the packing list. Any discrepancy between the parts list and the actual parts received should be reported to Temescal representatives. Inspect all parts for possible damage in shipping and verify that the gun is in good working order before disposing of its packaging. If you discover that the source has been damaged in shipment, report the damage immediately to the carrier and to the Temescal Service Department.

NOTE

To minimize vacuum system contamination, always wear rubber gloves or lint-free linen gloves when handling the source, any of its parts, or any other component that will be used in the vacuum chamber.

The PopTop SuperSource2 can be purchased either fully assembled or as a kit containing a base unit plus the parts required to make up a complete source. If you have purchased a fully assembled source, the shipping container should contain the assembled source plus the following items:

- two shunt bars
- one spare parts kit (PN 0627-3050-0) for the source
- one 7/64" Allen driver with specially machined sleeve
- one 10-24 × 1" × ¾" stainless steel thumbscrew

If you have purchased a kit with a base unit plus components, the shipping container should contain the items listed above plus the following:

- one base unit (i.e., a side- or bottom-drive source minus crucible, crucible cover, and emitter)
- one crucible
- one crucible cover
- one emitter assembly
- one spare parts kit for the emitter assembly

The available kits cover all combinations of drive styles (i.e., side drive or bottom drive), crucibles, and emitter assemblies.

NOTE

Base units as well as fully assembled guns ship with anti-cross-contamination inserts for both four- and six-pocket crucibles, regardless of which type of crucible is supplied as part of a particular order. The smaller, nearly cube-shaped copper inserts (PN 0715-8173-1) are for use with four-pocket crucibles, crucibles with one banana-shaped pocket, and continuous-trough evaporant carousels. The longer, arc-shaped inserts (PN 0715-8173-2) are for use with six-pocket crucibles. Take care not to lose or damage the 'extra' inserts (i.e., the set that is not for use with the crucible you will be using initially). You will need these inserts should you switch from four- to six-pocket operation or vice versa.

1.3 PRODUCT DESCRIPTION

General Characteristics

The STIH-270-2PT belongs to Temescal's SuperSource2 line of turret sources, which offer enhanced versatility, convenience, and dependability in applications ranging from optical and microelectronic production to specialized R&D coating. These enhancements result largely from the source's key feature, the vertical translation cover that prevents the crucible from seizing during rotation and blocks cross-contamination between the pockets during operation. Also, the easy removal of its crucible cover and crucible is another important feature (see Figure 1-1). Removing the crucible cover makes it easy to thoroughly clean the crucible and adjacent structures, particularly the cut-out above the exposed pocket. On conventional turret sources, it can be difficult to remove deposited evaporant along this cut-out without risking cross-contamination. Crucible cover removal makes it easy to clean this cut-out quickly and with no risk of cross-contamination. To further speed the resumption of production, many users keep a clean cover handy and simply replace the used cover with the clean one. The used cover can then be sent to a maintenance area for thorough cleaning and glass-bead honing.

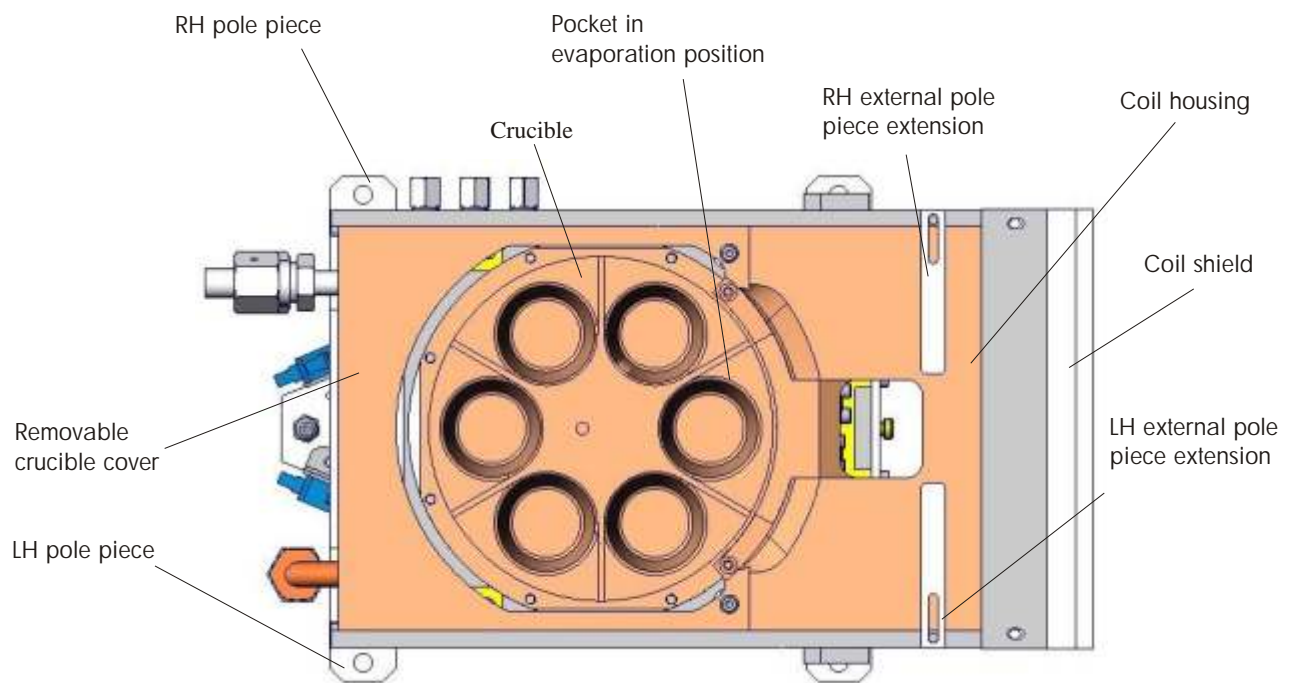

Figure 1-1. STIH-270-2PT source viewed from the top

Description and Specifications

Removing the crucible cover requires only raising the cover and removing the cover's three mounting screws. It is not necessary to blow the cooling water out of the source before removing the cover. Once the cover is off, crucible removal is relatively easy, though this operation does necessitate blowing out the source's water channels. If desired, the crucible can be immediately replaced with a crucible of a different configuration. This easy convertibility makes the PopTop SuperSource2 the most versatile source in its class.

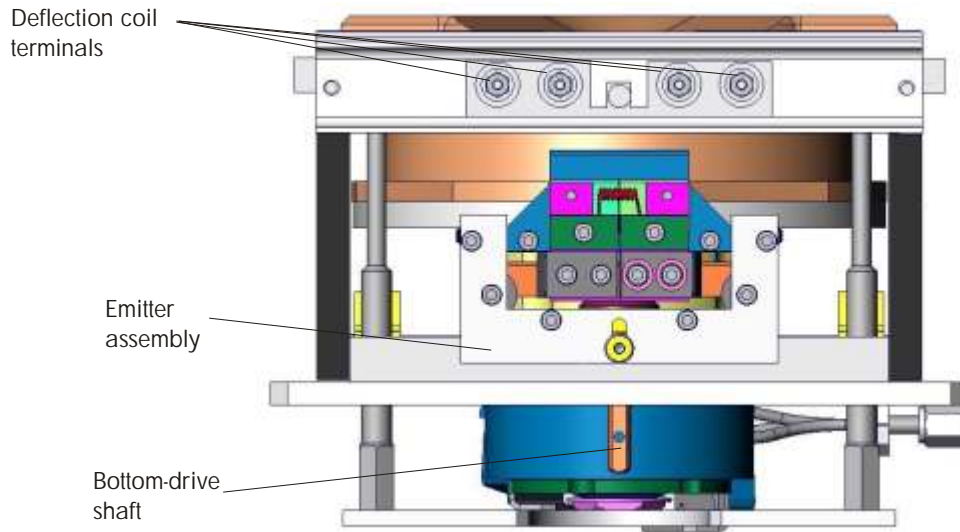

Figure 1-2. STIH-270-2PT source viewed from the front

Principal Features

Magnetic Beam Deflection

The source's main magnetic field is produced by a permanent magnet mounted at the rear of the source. Modified by the two pole pieces that form the sides of the source, this magnetic field bends the electron beam through its 270° arc and directs it into the exposed pocket. Within the scale of the pocket, the position of the beam can be more precisely controlled by fields generated by a set of electromagnetic deflection coils mounted in the front end of the source. These fields also affect the beam's shape and concentration, which are further influenced by two sets of adjustable pole piece extensions. One set of these extensions is mounted on top of the source, while the other extends inside the body of its coil housing.

Emitter Assembly

The electron beam is generated by the emitter assembly mounted at the front of the source. The primary functional parts of the emitter are an electron-emitting filament and a beam former. The filament is easily replaced, and the entire emitter can be quickly disassembled for cleaning.

A filament should last for 100-plus hours of operating time when the source is used for evaporating metals. Shorter filament lifetimes can be expected when the unit is used for evaporating dielectric materials, as such processes create an area of localized high pressure near the filament. For all other applications, short filament

life is attributable to two causes. The first and most common is improper installation of the filament. The second is incorrect use of a deposition-rate controller. The person setting up the process parameters must ensure that the maximum signal output by the rate controller will never drive the source beyond its maximum rating of 10 kW. If the rate-request signal remains too high for too long, the filament can burn out as a result of excess power.

High-Performance Emitter

The optional high-performance emitter assembly is designed to improve dependability, coating uniformity, and run-to-run repeatability. With its thicker-gauge filament, this new emitter offers filament lifetimes two to three times as long as those of conventional emitters. In addition, the new design improves the positional stability of the filament, the beam former, and the anode. These improvements, in turn, enhance the stability of beam optics and reduce the possibility of anode-beam former contact, which can short out the emitter. The net benefits for the user are improved uniformity and reliability.

Drive Assembly

The source is designed so that when one pocket is in the 'home' position, the others are shielded by the crucible cover. A ring gear fixed to the bottom of the crucible mounting flange mates with the gear on the end of the drive shaft, whose other end accepts a mechanical coupling. On the side-drive model, this end of the drive shaft extends horizontally from the housing. On the bottom-drive model, the drive shaft extends toward the source's baseplate. On both models, one turn of the drive shaft produces one-quarter turn of the crucible.

Cooling System

Water circulates through channels in the baseplate and the coil housing to ensure adequate cooling during operation. The SuperSource2 provides improvements in the water channel that enhance the direct crucible cooling that has always been a feature of Temescal SuperSources. The water inlet and outlet are located on the rear of the source.

Spare Parts Kit

The spare parts kit (PN 0627-3050-0) for the source contains extra 6-32 socket-head screws as well as replacements for O-rings and the gun's single quad ring.

Description and Specifications

Ordering Additional Crucibles

The table below lists the part numbers for the crucibles and crucible covers currently available for the STIH-270-2PT.

FOUR-POCKET CRUCIBLES

<u>DESCRIPTION</u>	<u>PART NO.</u>
four 15-cc pockets	0715-8444-0
four 25-cc pockets	0715-8454-0
two 7-cc pockets + two 15-cc pockets	0715-8464-0
two 15-cc pockets + two 25-cc pockets	0715-8494-0
three 15-cc pockets + one 25-cc pockets	0715-8484-0
three 25-cc pockets + one 15-cc pocket	0715-8244-0
one 7-cc pocket + one 15-cc pocket + two 25-cc pockets	0715-8474-0

SIX-POCKET CRUCIBLES

<u>DESCRIPTION</u>	<u>PART NO.</u>
six 7-cc pockets	0715-8514-0
six 15-cc pockets	0715-8504-0
three 7-cc pockets + three 15-cc pockets	0715-8524-0

CRUCIBLE COVERS

<u>DESCRIPTION</u>	<u>PART NO.</u>
Cover for use with 4-pocket crucibles	0627-8144-1
Cover for use with 6-pocket crucibles	0627-4854-1

1.4 SPECIFICATIONS

Dimensions	See drawings
Weight	40.4 lbs. (18.3 kg)
Rotation torque	10 in.-lbs. (11.5 kg-cm)
Maximum bakeout temperature	302° F (150° C)
Maximum power	10 kW
Acceleration voltage	4-10 kV
Operating pressure range	
Maximum	5×10^{-4} torr (6.7×10^{-4} mbar)
Minimum	1×10^{-8} torr (1.33×10^{-8} mbar)
Evaporation rate	25,000 Å/min. of Aluminum at a source-to-substrate distance of 10 inches (254 mm)
Beam characteristics	
Deflection	270°
Range of spot size/shape	From tight oval beam to diffuse oblong beam
Sweep capability	Longitudinal and lateral when operated with a sweep controller
Installation requirements	
Power	
Filament current	70 A at 12 V ac
Emission current	0-1.5 A at 4-10 kV dc (10 kW max.)
Cooling water	
Max. Temperature	68° F (20° C)
Flow rate	3.0 gpm (0.19 liter/sec)
Max. inlet pressure	100 psi (6890 mbar)
Min. pressure differential	50 psi (3445 mbar)
Feedthroughs	2 high-voltage feedthroughs rated for 12 kV at 70 A 1 octal feedthrough rated for 600 V at 15 A per lead 1 air/water feed-through with two 3/8" (9.5-mm) OD water tubes and three 1/8" (3.18-mm) OD air tubes 1 rotary-motion feedthrough with a 1/4-in. (6.4-mm) diameter shaft

Description and Specifications

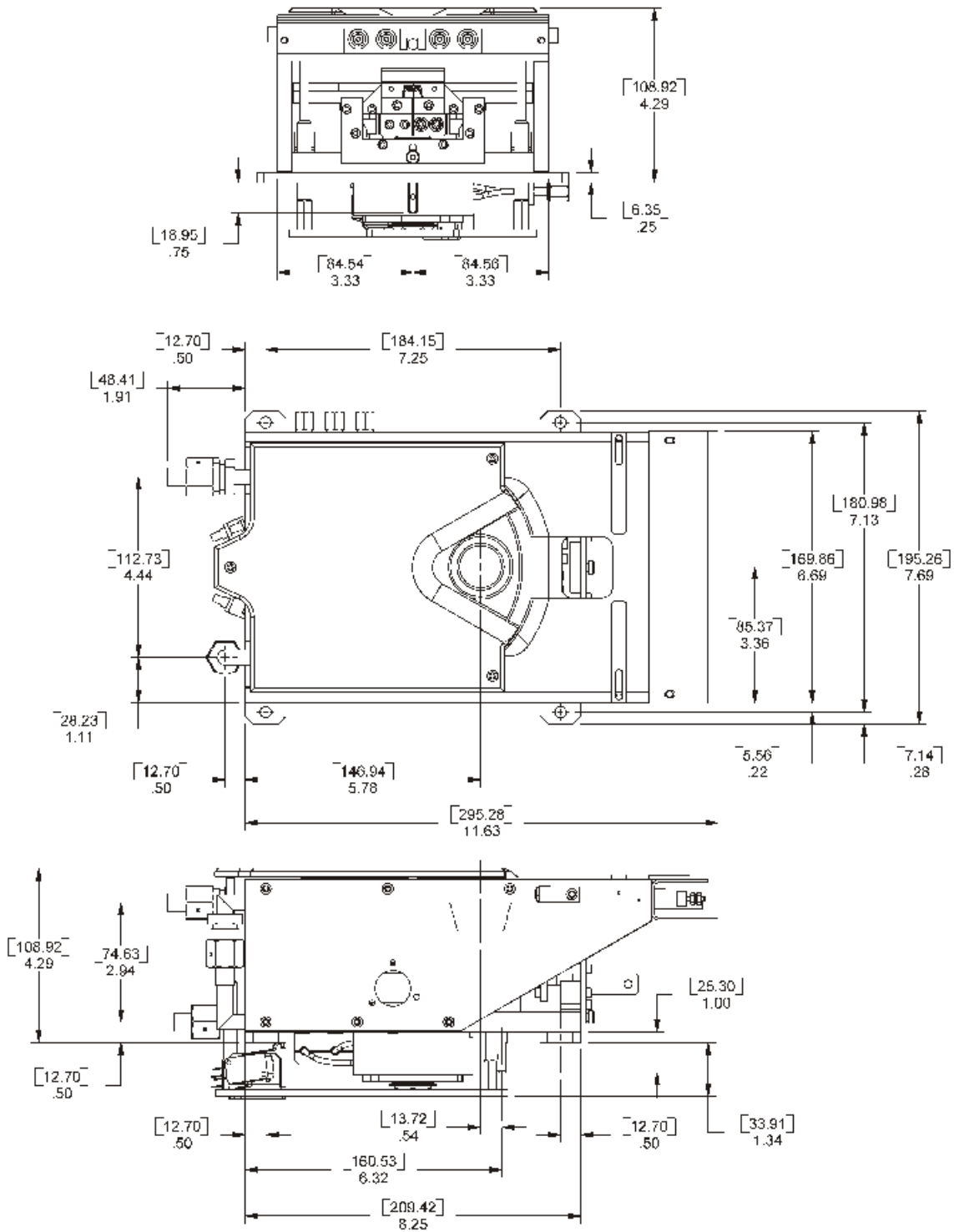

Figure 1-3. Dimensions of STIH-270-2PT source - top, side, and front views

1.5 ACCESSORIES

Feedthroughs

The feedthroughs described below are required for installation of the PopTop SuperSource2.

1. The high-current octal feedthrough, which provides the conduit from atmosphere to vacuum for the deflection coil current.

The ordering number for the octal feedthrough is:

1"-dia. O-ring-sealed octal 6047-5808-0

2. Two high-voltage feedthroughs, which provide the conduit from atmosphere to vacuum for the power supplied to the emitter assembly.

The ordering numbers for high-voltage feedthroughs are:

1"-dia. O-ring-sealed HV feedthrough 0715-9033-0

3. One air/water feedthrough, which provides the conduit from atmosphere to vacuum for the source's cooling water and pneumatic cylinder. It is O-ring sealed (PN 0629-0780-2). An adjustable flow switch is provided. The maximum pressure rating is 100 psig (7.0 kg/cm²).
4. One rotary-motion feedthrough (PN 9999-0013-1). The rotary drive connected to this ferrofluid-type feedthrough can be either manually operated or motor driven. Note that even with a manually rotated source, an external indexing mechanism is required to raise and lower the cover in addition to ensure that the crucible can reliably be positioned with a pocket in the correct 'home' or evaporation position.

Turret Indexer Controller

Temescal's TRC-3460 turret indexer controller (PN 0040-9380-0) features manual and automatic pocket selection, forward and reverse rotation, and electronic phase adjustment via its front panel. The TRC-3460 can be configured for use with a wide variety of crucibles, including 4-, 6-, and 8-pocket crucibles, crucibles with various combinations of circular pockets and banana-shaped troughs, and continuous-trough evaporant carousels.

Beam Sweep Controller

The Temescal SS64 (PN 0611-8570-0) is a programmable beam sweep controller that is compatible with all Temescal e-beam sources. The unit's proprietary Windows-based software enables users to simulate and modify beam sweep programs on a PC before downloading them to the SS64. Alternatively, users can employ a hand-held remote control box to modify sweep programs in real time. Variable sweep program parameters include amplitude, frequency, position and offset, emission current, and waveform. Four waveforms (sine, triangle, sawtooth, and clipped) are predefined and preloaded in the unit, which provides for an additional, arbitrary, user-defined waveform. The SS64 can store up to 64 user-defined sweep programs, while a virtually unlimited number of such programs can be stored on PC-based computer media.

Deposition Shutter Kit

A complete deposition shutter kit (PN 0413-4313-0) is available from Temescal. This kit includes the shutter actuator mechanism, and a rotary-motion feedthrough for the shutter drive. Numerous combinations of shutters and shutter arms are available. Contact Temescal Sales for assistance in ordering these items.

Dual Shutter Controller

Control units designed to control either one or two shutters are available from Temescal. For the single-shutter controller, order PN 0611-4810-0. For the dual-shutter controller, order PN 0611-4810-1.

Crucible Liners

The optional crucible liners available from Temescal increase evaporation rates by reducing heat transfer between the evaporant and the water-cooled crucible. They also allow particulate-free pocket replenishment and reduce the risk of cross-contamination when one material replaces another in a given pocket. Liners are available in the following materials:

1. **Molybdenum.** These are high-strength inserts machined from solid-rod molybdenum. When considering the use of these liners, users should be aware that some metals alloy with molybdenum.
2. **Tungsten.** In most respects, tungsten liners are suitable for the same range of applications as molybdenum liners. The one significant difference is that tungsten has a higher melting point than molybdenum.
3. **Graphite.** These liners are machined from ATJ-grade solid-rod graphite. Materials such as pure gold, silver, and copper do not alloy with graphite and are easily removed from the insert.
4. **POCO graphite.** Liners made of this material are effective in aluminum evaporation processes. Their use impedes the formation of aluminum carbide.

For information on available sizes and ordering numbers, consult the current Temescal price list.

SECTION 2 INSTALLATION

2.1 SECTION OVERVIEW

This section provides the information required for source installation. Section 2.2 lists the installation requirements. Section 2.3 describes the procedures for installing a STIH-270-2PT alone on a source tray, and section 2.4 provides additional instructions to be followed when the source is installed next to another source on one source tray.

NOTE

Read the following specifications and instructions carefully before installing the source. The installation procedures and safety precautions described below are very specific, and must be adhered to closely. Taking a casual attitude toward any of these measures may result in inefficient or unsafe source operation. Bear in mind that the source is powered by a high-voltage power supply with its own installation and safety requirements. Consult the power supply's manual for additional information relating to source installation and interconnection, paying particular attention to instructions concerning interlocks.

2.2 INSTALLATION REQUIREMENTS

Feedthroughs

The feedthroughs listed below are required for installation of the source. They are available from Temescal. See section 1.4 for descriptions and ordering numbers.

- One air/water feedthrough
- One octal feedthroughs rated for 6 A at 600 V
- Two high-voltage feedthroughs rated for 1.5 A at 12 kV dc and 70 A at 12 V ac
- One rotary-motion feedthrough.

Additional Components

- Tubing for connecting the water feedthrough to the source. Use 3/8" (9.5 mm) OD tubing made of type-304 stainless steel or copper.
- Tubing for connecting the air lines to the pneumatic cylinder. Use 1/8" (3.18-mm) tubing made of Type 304 stainless steel.
- Two 3/8" OD rubber ferrule fittings. These attach to the water feedthrough's atmosphere-side tubing and can be removed from the tubing without damaging it. (Available from Temescal; order PN 3763-6809-0.)
- Two 3/8" OD barbed connectors, which connect to the external water supply and return hoses. (Available from Temescal; order PN 3780-3088-6.)
- Two 45° × 3/8" NPT flare connectors. Each of these attaches to a rubber ferrule fitting on one end and to a barbed hose connector on the other. (Available from Temescal; order PN 3770-4964-0.)
- An air installation kit (available from Temescal, order PN 0627-3010-0)
- #16-AWG Kapton wire to connect the octal feedthrough to the deflection coil. (Available from Temescal; order PN 6342-1916-1.)
- High-temperature lugs for connecting the Kapton wire to the terminals on the deflection coil. (Available from Temescal; order PN 6044-0359-0.)
- Bare #6-AWG flexible copper wire for connecting the high-voltage feedthroughs to the emitter assembly. Ready-made filament leads, complete with termination hardware on both ends, are supplied with the source.
- High-voltage cable for connecting the atmosphere side of the high-voltage feedthrough to the gun filament transformer. This cabling is generally supplied with the electron-beam power supply. For users who do not have this highly specialized cable on-hand, a complete cable assembly is available from Temescal (order PN 0040-8140-0). This assembly includes appropriate termination hardware on both ends of the cable and connectors and brackets for securing the ends of the cable.
- A system for rotating the crucible. For manual-drive systems, this system will include a mechanism for rotating the crucible, a means of indexing this mechanism to the correct evaporation or 'home' position for the exposed pocket, and hardware for connecting the index/drive mechanism to the atmosphere side of the rotary-motion feedthrough. For automated indexing, Temescal's TRC-3460 Turret Indexer Controller is recommended. For best results with either manual or automated turret drive, use flexible couplings (PN 9015-0121-1) when making connections to both ends of the rotary-motion feedthrough.

DANGER: HIGH VOLTAGE

On manually driven systems, the knob or crank for rotating the source must NOT be mounted in a position that would place an operator in proximity to any high-voltage component. Injuries resulting from high-voltage shocks can be extremely severe, even lethal.

- A water-flow switch that can be connected to the gun water interlock on the e-beam power supply. This switch should be set up so that the interlock is made only as long as the water pressure remains above 3.0 gallons per minute (gpm). A suitable water-flow switch is included with the Temescal's air/water feedthrough kit when that feedthrough is ordered under PN 0629-0780-2.
- A pressure interlock that will prevent the high voltage and the filament current from being on when the vacuum chamber's pressure is higher than 5×10^{-4} torr.

Optional Accessories

The following items may be required for operation of the source, depending on the application and on other installation details.

- Any additional interlock switches deemed necessary or desirable by the user.
- A source shutter assembly, consisting of a shutter arm and a shutter, plus a rotary-motion feedthrough for the shutter drive, a shutter actuator mechanism, and a shutter controller. (See Section 1 for ordering numbers.)
- Some form of shielding to prevent loose material in the vacuum chamber from coming into contact with high-voltage components. Over a period of time, evaporant material accumulates on the inner surfaces of the chamber. As this material flakes off, some of it will fall onto high-voltage components unless they are shielded, resulting in severe arcing. The preferable solution is to install full debris shields, which fit tightly around the top of the source and extend to the chamber walls. If your system will not have full debris shields, then it is essential to install a smaller shield like that shown in Figure 2-2 over the high-voltage leads.
- A shield for secondary electrons. When the source is used to evaporate materials with high atomic weights, such as tungsten or gold, numerous electrons may bounce off the evaporant pool and be deflected over the rear of the gun. These electrons, which are known as *secondary electrons*, may strike the water lines or the nearby chamber wall, damaging either or both over time. If your application entails this hazard, a copper shield should be mounted so that it extends above the rear of the source.
- A magnetic shield, if two sources are being installed on one source tray. The purpose of this shield is to prevent mutual magnetic interference between the two sources. It should be made of thin sheets of mumetal and stainless steel loosely bolted together. Figures 2-5 and 2-6 illustrate two methods of installing such a shield.

Source Cooling Water

Cooling water at 20°C must be supplied to the source at a minimum rate of 3.0 gpm.

CAUTION

Inadequate water flow may result in severe damage to the crucible. Damage resulting from an inadequate supply of cooling water is not covered by the gun's warranty.

Electrical Power

To produce an electron beam, the source must be powered by an electron-beam power supply capable of providing up to 35 A of filament current at 12 V ac and up to 1.5 A of emission current at 4-10 kV dc (10 kW max.). A separate circuit must supply up to 4 A ac at 13 V ac to the gun's deflection coils. On systems without beam sweep control, this power is supplied by the e-beam power supply. If beam-sweep control is desired, the deflection coil current must be supplied by a beam sweep controller.

2.3 INSTALLATION PROCEDURE

Follow the procedures described below and refer to Figure 2-1 in installing the source.

NOTE

The source should be mounted ONLY on a source tray made of type-304 stainless steel or some other nonmagnetic material. Mounting the source on a magnetic material will severely distort the source's magnetic field.

Procedure 1: Lay Out the Source Tray

First determine the gun's precise mounting position on the source tray. The optimal location depends on several factors:

- Both bottom- and side drive guns must be mounted with adequate space available for the pneumatic cylinder and spider plate to function.
- The exposed pocket must be positioned correctly with respect to the system's substrate fixturing.
- The operator must have a clear view of the exposed pocket through the viewport. On systems with deposition shutters, the viewport must be low enough to allow a clear line of sight beneath the shutter. On such systems, providing a clear line of sight over the raised crucible cover will require positioning the source with its front end pointing from 30° to 60° away from the viewport. On systems without deposition shutters, the viewport can be mounted as high as desired, so the source can be positioned at almost any angle with respect to the viewport. However, for safety reasons, the source should never be mounted so that either its front or rear end faces a viewport.

DANGER

Do NOT mount the source so that the viewport is either directly in front of the source or directly behind it. Under certain conditions, the full-strength electron beam can be directed toward those areas. The result could be severe injury to anyone looking through the viewport.

- The *top is down* switch must be adjusted so that the switch changes state when the cover is down, fully seated on the coil housing.
- There are additional requirements if two sources are to be installed on one source tray. See section 2.4 for a description of these requirements.

Next determine where the feedthroughs will be mounted, as their placement depends on where the source is mounted. The air/water feedthrough should be somewhere behind the source. The high-voltage feedthroughs should be mounted beside each other somewhere in front of the source, or perhaps slightly off to one side, as shown in Figure 2-1. The octal feedthrough should be mounted off to the other side of the source, ideally as far from the high-voltage feedthroughs as possible. Do NOT mount all three electrical feedthroughs in front of the source, with the octal feedthrough positioned between the two high-voltage feedthroughs. This mounting arrangement makes it impossible to isolate the coil-current leads from the effects of the high-voltage. It is critical to provide this protection for the deflection coil leads. This can be accomplished simply by mounting the octal so that the deflection coil leads run along the lower lip of the coil shield and toward the side of the gun opposite the high-voltage feedthroughs, as shown in Figure 2-1. With the leads routed this way, the coil shield provides adequate isolation from the high voltage. If the coil shield cannot be used to provide the required isolation, it will be necessary to install a stainless steel high-voltage shield like the one shown in Figure 2-2.

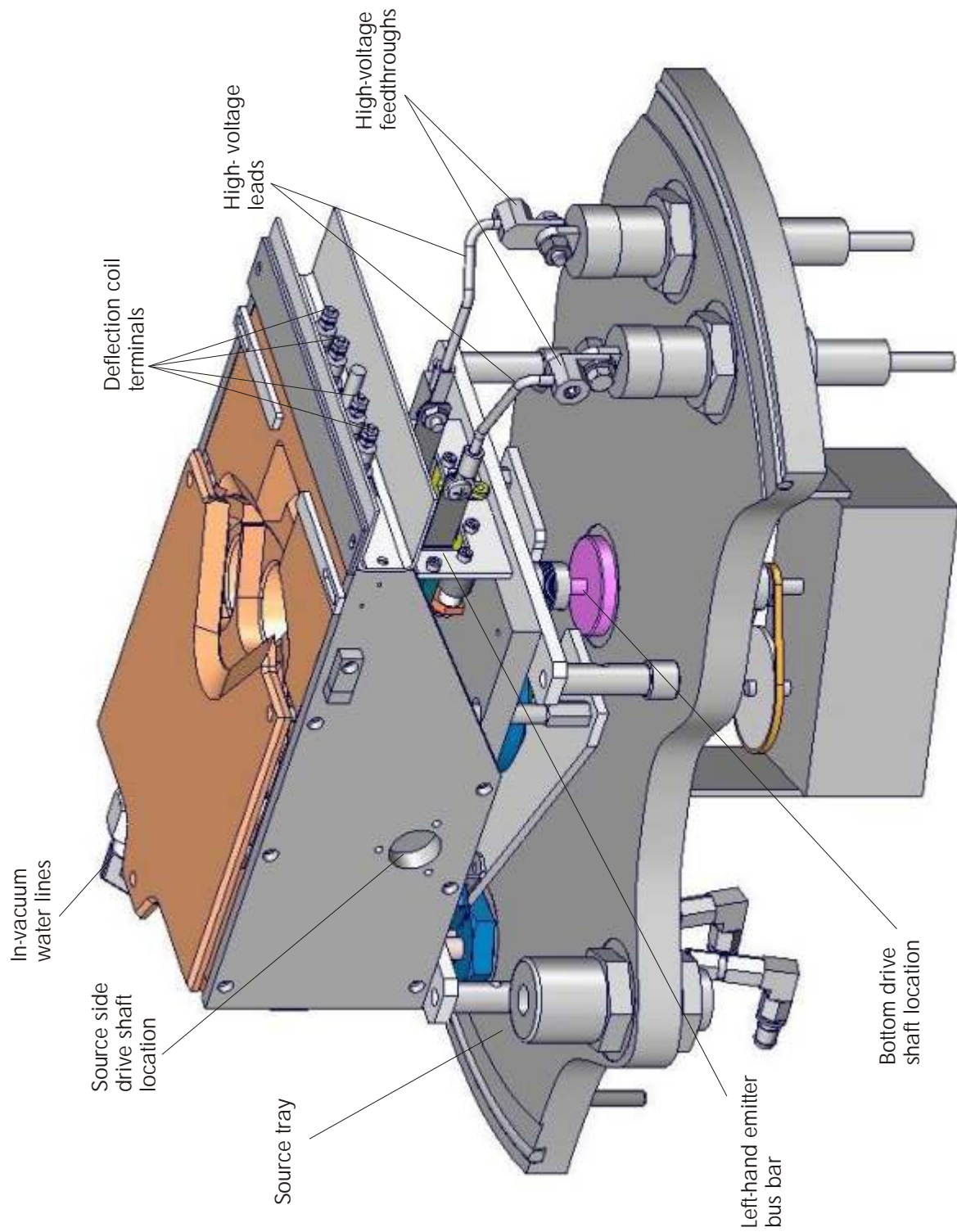

Figure 2-1. Installation Details

CAUTION

It is critical to isolate the coil-current leads from the effects of the high voltage. If adequate isolation is not provided for these leads, the probable results included erratic beam position control and damage to other system components. Beam sweep controllers are particularly vulnerable to the effects of high-voltage interference and arcing.

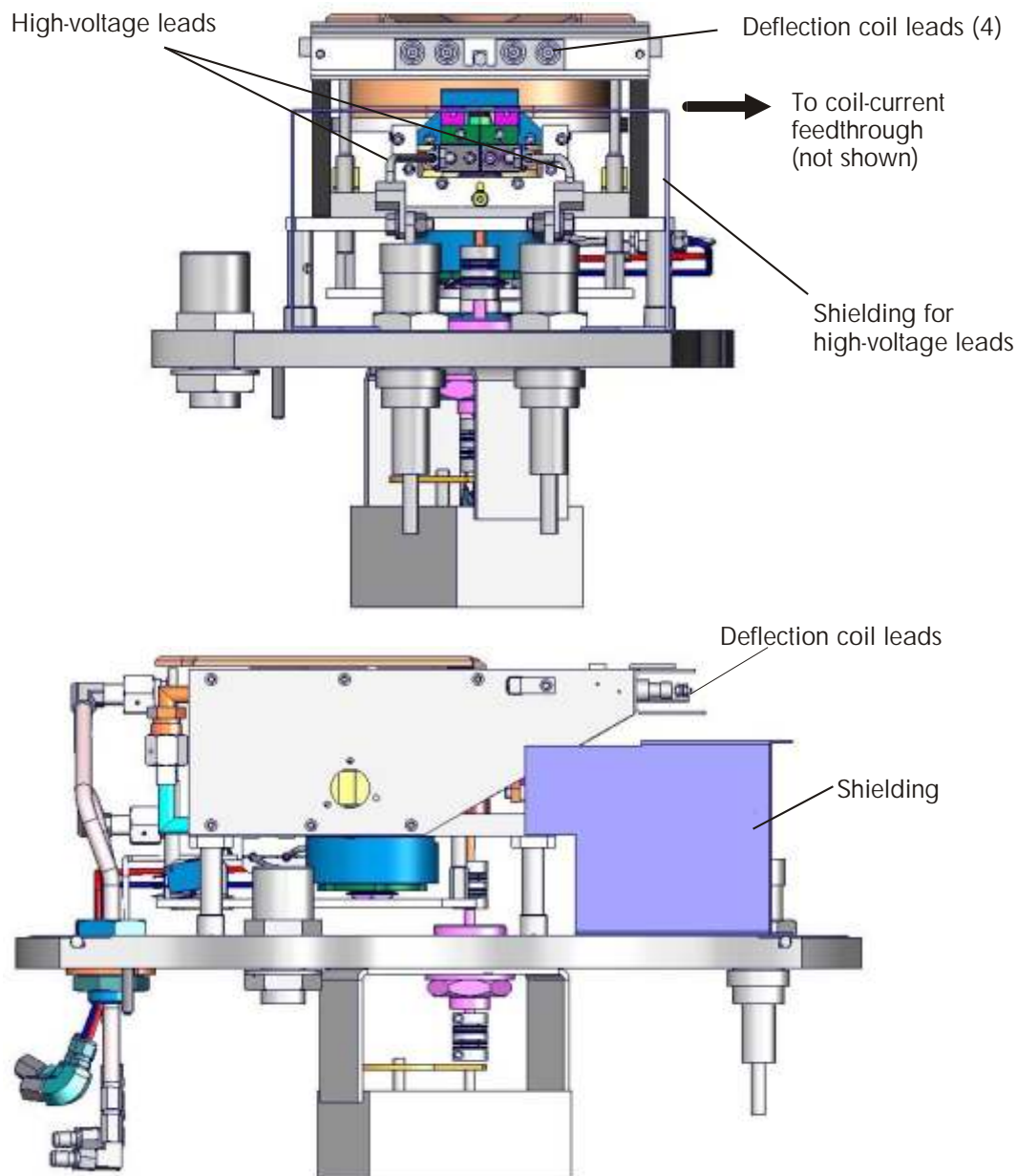

Figure 2-2. Correct placement of high-voltage shielding

The rotary-motion feedthrough must be located rather precisely with respect to source location. In side-drive installations, the rotary feedthrough is ideally mounted in a straight line with the gun's drive shaft. Since this is difficult to achieve with precision in practice, the coupling and shaft extension used must provide enough flexibility to compensate for whatever degree of misalignment exists between the feedthrough and the gun's drive shaft. For this reason, the use of a flexible drive shaft extension and flexible coupling PN 9015-0121-0 is recommended. Side-drive and bottom-drive guns must be mounted on stand-offs at least 2.5" high to provide clearance for the rotary-motion feedthrough and coupling. On bottom-drive guns, this clearance is also required for the popstop mechanism. The additional height of the source may affect the positioning of substrate fixturing, viewports, deposition shutters, crystal monitors, and other in-vacuum components.

Procedure 2: Mount the Source

1. Once you have determined the optimal mounting location for the source, mark the locations for the mounting holes, using the holes in the mounting straps as your guides.
2. Make sure that the source tray is level, as the source will not operate correctly if it is not level.
3. Drill the mounting holes in the source tray then clean the source thoroughly.
4. If you are mounting a bottom-drive source, install the rotary-motion feedthrough.
5. Put a flexible coupling in place on the feedthrough's output (i.e., vacuum-side) shaft and tighten down the set screw that secures the coupling to this shaft.
6. Set the source in its mounting position. If you are installing a bottom-drive gun, make sure that the gun's drive shaft extends into the upper end of the coupling fixed to the rotary feedthrough. Then tighten the coupling's upper set screw.

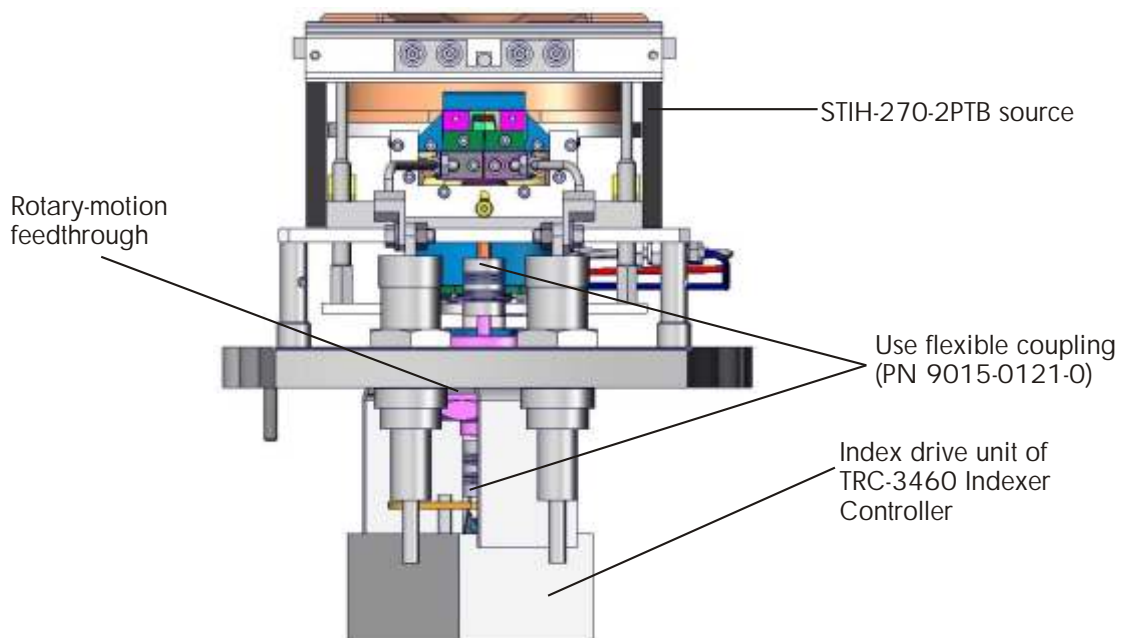

Figure 2-3. Typical installation of bottom-drive model (STIH-270-2PT)

7. Make sure that the drive coupling is not bent and that the shafts it connects are in line with each other. Then install and tighten the gun's mounting screws. The gun's mounting straps must make tight, solid contact with the source tray, providing a secure path to ground for the high-voltage current that will pass through the gun.

Procedure 3: Install the Air/Water Feedthrough and the Air/Water Supply/Return Lines

There are two main choices when installing the Air and Water feedthrough(s). One feedthrough can be used that contains both the three air lines and the two water lines. A second option is to use two separate feedthroughs, one for the three air lines and another for the two water lines.

If this source is being installed as a replacement for an existing turret source and it is possible to re-bend the existing water lines to fit the new source, less work would be required to use the existing water feedthrough. A second feedthrough would then be installed in a separate hole for use with the air lines. An unused hole in a suitable location would be required for the second feedthrough.

If this is a new installation or the existing water feedthrough will not work with the new source then either a combination air/water feedthrough or two separate feedthroughs could be used. The combination air/water feedthrough will take up less space and only requires a single feedthrough hole.

1. Before installing a feedthrough for fitting up and fabricating the lines, it is best to remove the o-ring so the feedthrough sits flush to the mounting surface.
2. Put a feedthrough in place in the source tray, but do not install its mounting nut.
3. Check to see whether the tubing on the in-vacuum side of the water feedthrough is long enough to reach the threaded unions on the gun's water lines and the air lines are long enough to reach the air cylinder ports at the base of the gun. If it appears that these air and water lines will be long enough after all the necessary bends have been made, skip this step and proceed to step 4. If not, you will have to splice on an additional length of 1/8" or 3/8" OD tubing. The material for these extensions is type-304 stainless steel tubing. Add stainless steel extensions by TIG welding, using suitable sockets or unions over the joints. Do all welding outside the vacuum chamber, and remove the O-ring from the air/water feedthrough before applying any heat. In addition, make sure that all surfaces to be joined are bright clean before joining them. Use abrasives as needed to obtain the appropriate finish.
4. Reinstall the air/water feedthrough in the source tray, with its mounting nut installed but only finger tight. Do not replace the O-ring yet.
5. The source should have arrived with the connecting nuts screwed onto the water intake and outlet lines on the rear of the source. Unscrew the connecting nuts and remove the tubing nipples inside.
6. Make the bends required to make the in-vacuum tubing reach the threaded unions on the gun's air/water lines. The bends should be such that there is no tension on the tubing when all connections have been made, and no bend should be closer than 1/2" to either end of the in-vacuum tubing. A final right-angle bend should turn each length of tubing horizontal, with its end just touching the junction to which it is to be connected.
7. When you have made all the required bends, remove the feedthrough-tubing assembly from the vacuum chamber.
8. Find the connecting nuts and the tubing nipples you removed in step 6.
9. Fit the connecting nuts over the ends of the feedthrough's in-vacuum tubing, making sure that the threaded end faces the end of the tubing.

10. Attach the tubing nipples to these tubing ends. If the tubing is stainless steel at the ends, use TIG welding to attach the nipples.
11. Coat the O-ring with Apiezon L grease and replace it in the groove in the air/water feedthrough.
12. Reinstall the feedthrough-tubing assemblies, tightening the feedthrough's fixing nut all the way this time.
13. Begin screwing the connecting nuts on the tubing ends onto the threaded unions on the gun's water lines. You should be able to do so without putting any tension on the feedthrough's in-vacuum tubing. If making this connection requires applying any force to this tubing, readjust the bends in the lines to eliminate all tension on the tubing.
14. Make the atmosphere-side connections for the water supply and return lines. If you are using the hardware available from Temescal, first connect the rubber ferrules to the 45° × 1/4" NPT flare connectors. Then connect the ferrules to the atmosphere-side tubes of the water feedthrough. Finally, connect the barbed hose connectors to the supply and return hoses and screw the barbed connectors onto the flare connectors contained in the air system kit PN 0627-3010-0.
15. Make the atmosphere side connections for the air supply and return lines using the parts.

CAUTION 1

To ensure proper cooling, the water lines MUST be connected as shown in Figure 2-1, with the supply line connected to the gun's lower external water junction and the return line connected to the gun's upper external water junction. The crucible will not be cooled adequately if these connections are reversed.

CAUTION 2

When connecting the three 1/8" SST tubes from the feedthrough to the gun, the vent line, which is the line immediately terminated on the atmosphere side of the feedthrough, must be connected to the vent line of the air cylinder. The "V" in the clamp block denotes the vent line.

NOTE

Connecting the vent line to a source of pressurized air will result in damage or failure of the bellows on the air cylinder.

Procedure 4: Install the Turret-Drive Components

1. If you are mounting a side-drive source, install the rotary-motion feedthrough at this time. If you are installing a bottom-drive source, skip this step and step 2 and proceed to step 3.
2. Connect the gun's drive shaft to the rotary feedthrough's output (i.e., vacuum-side) shaft. On side-drive sources, you may need to add an extension shaft like that shown in Figure 2-1 between the gun's drive shaft and the rotary feedthrough. Connecting a side-drive source to a rotary feedthrough mounted in the source tray will require a right-angle coupling. In all other cases, use a flexible in-line coupling (PN 9015-0121-0) to connect the shafts.

3. Using a flexible coupling, connect the rotary feedthrough's input (i.e., atmosphere-side) shaft to the output shaft of the index/drive mechanism. If you are using the Temescal model TRC-3460 Turret Indexer Controller, follow the instructions in the indexer's manual in making this connection.

Procedure 5: Install the Deflection Current Circuit

1. Remove the black connector from the bottom of the octal feedthrough.
2. Remove the metal cap from the plastic body of this connector. To do so, insert a flat-bladed screwdriver into one of the rectangular slots at the top of the cap and gently pry against the flange that forms the top of the plastic connector. Pry the cap loose as far as you can using this slot, then insert your screwdriver in the other slot in the cap and repeat the process. If necessary, once a gap is visible between the cap's top edge and the connector's top flange, you can insert the screwdriver into this gap and pry the cap the rest of the way loose. When prying, take care not to damage either the thin metal of the cap or the plastic of the connector body.
3. Strip about 1/8" of insulation from the ends of the eight wires you will be using to connect the feedthrough to a terminal strip in the vacuum cabinet.
4. Insert the stripped wire ends through the metal cap you just removed. If necessary, loosen the clamp screws on the bottom of the cap.
5. Note the numbers next to the metal terminals molded into the plastic connector. Solder the stripped wire ends to terminals 1 through 8.
6. Snap the metal cap back into place on the plastic connector and push this assembly back onto the bottom of the feedthrough. Note that the shaft in the center of the feedthrough is keyed, so that the connector can only go on one way.
7. If necessary, tighten the clamp screws on the bottom of the metal cap.
8. Measure and cut suitable lengths of the Kapton-insulated wire, you will be using as in-vacuum leads for the deflection coil current.
9. Strip about 1/8" of insulation from both ends of these leads, then crimp and solder lugs onto one end of each wire. The lugs for the deflection coil should be high-temperature ring-type lugs for use with 6-32 machine screws. The terminals use female, quick disconnects.
10. Measure and cut four lengths of Kapton-insulated wire then strip the ends for the pop top "is down" and "is up" switches.
11. Using a 1/16" Allen wrench, loosen the three set screws that secure the metal cap to the ceramic connector on top of the octal feedthrough and remove the cap.
12. Remove the ceramic connector from the top end of the feedthrough. Note the numbers molded into the raised ceramic ring that surrounds the circle of metal terminals molded into the ceramic of this connector.
13. Solder the bare wire ends of the Kapton-insulated ring lug leads to terminals 1 through 4, and solder the pop-top limit switch wires to terminals 5 through 8.
14. Attach the lugs on the other end of these leads to the deflection coil terminals. The legends stamped into the top surface of the coil shield indicate which terminals are connected to the lateral coils and which are connected to the longitudinal coil. The polarity of the longitudinal coil's terminals is indicated on the same surface. Note which wires are connect to which coil terminals, and note which numbered feedthrough terminal each of these wires connects to.

15. Connect the *top is down* switch N.O. to pin 8, common to pin 7, and connect the *top is up* switch N.C. to pin 6, common to pin 5.
16. Find the loose ends of the wires that you earlier connected to the atmosphere side of the octal feedthrough.
17. Connect the deflection coil wire ends to a terminal strip or to whatever connector will serve as a junction point between these wires and those from the device that will be supplying the deflection coil current. Follow the connections back to the deflection coil terminals and note which wires are connected to which coils. Refer to Temescal customer service for the termination location of the switch wires that originate from the BLANK feedthrough.
18. Find the cable from the device that will be supplying the deflection coil current for this source. Connect the wires in that cable to the terminal strip to which you just connected the wires running from the octal feedthrough. If the device supplying the deflection current is an e-beam power supply or a non-bipolar beam sweep controller, the polarity of the longitudinal coil connections is important. If the external device is a bipolar beam sweep controller, the polarity of the longitudinal coil connections does not matter. For more detailed instructions on making these connections, refer to the manual for the external device.

CAUTION

If the device supplying the deflection coil current is either an e-beam power supply or a non-bipolar beam sweep controller, the coil's negative terminal MUST be connected to the common line, and the coil's positive terminal MUST be connected to the 'hot' or control line. The source can be damaged if these connections are reversed. The gun's warranty does NOT cover damage resulting from operation with the longitudinal coil leads connected the wrong way around.

Procedure 6: Installation and Setup of the *Top is Up* and *Top is Down* Limit Switches

1. Two limit switches are located in the back of the e-gun. Wire the limit switches to the octal feedthrough using white Kapton wire (PN 6342-1916-1). Silver solder the wires to the octal feedthrough on the vacuum side of the source tray.

NOTE

Prior to rotating the crucible to another pocket the *Top is Up* condition must be met. Likewise, the *Top is Down* condition must be met prior to considering the new pocket has been found.

Procedure 7: Install the High-Voltage Circuit

1. Install the high-voltage feedthroughs in the source tray, if you have not already done so.
2. Find the high-voltage leads supplied with the source. Each of these leads has a lug crimped onto one end. Connect these lugs to the emitter bus bars, using the nuts and bolts provided with the leads.

3. Route the leads to the high-voltage feedthroughs and cut them to length. Route each lead to the nearest feedthrough, without crossing them and with no sharp bends. The leads must NOT touch the source tray or any other grounded component or structure.
4. Attach the supplied terminals to the ends of the leads and connect the terminals to the HV feedthroughs.
5. If you have not already done so, connect the atmosphere-side high-voltage cables to the terminals on the lower ends of the high-voltage feedthroughs and to secondary side of the gun filament transformer. Be careful in routing these cables. They should be loose, rather than taut, with no sharp bends, and they should not run over any sharp edges or close to any heat-generating components. Make sure that these cables are securely clamped near their ends to adjacent structures. On the feedthrough end, the cables are generally secured to the feedthrough itself. On the transformer end, the cable can be secured to a frame member or to some other adjacent structure.

DANGER

The exposed ends of the high-voltage cables present a severe, even lethal, hazard. This hazard is much more serious if the cables are not properly secured near their ends.

Procedure 8: Install Optional Equipment

1. If your source tray is not fitted with full debris shields, install a shield that will cover the in-vacuum high voltage leads and as much of the emitter assembly's filament bus bars as possible (see Figure 2-2). This shield should be made of type-304 stainless steel, and it should be placed so that no part of it is closer than 1/4" to either of the high-voltage feedthroughs. There should be no grounded components within the shielded area.
2. Install a deposition shutter and supporting hardware, if such is required for your application. The shutter must be at least 1.5" above the top of the crucible.
3. Install secondary electron shielding. at least 5" (127 mm) high should be installed at the rear of the gun.

Procedure 9: Install Interlocks

Connect all protective interlocks. The minimum required interlocking includes the following:

- a chamber pressure interlock that prevents the filament current and the high-voltage from being on when the pressure is higher than 5×10^{-4} torr
- a water pressure interlock that prevents the filament current and the high-voltage from being on when the water pressure is lower than 3.0 gpm
- an interlock that prevents the filament current and the high-voltage from being on if the vacuum chamber door or the door(s) on the vacuum cubicle are open.

Procedure 10: Connect the Source Tray to a Low-Impedance Ground

The source operates at extremely high voltage with respect to earth ground. It can therefore place ungrounded elements at dangerous potential. This potential varies directly with the coupling between the source, the components, and the impedance to ground. Make sure the earth ground to the building (and hence to the system) is at zero resistance. The building's water pipes will generally not provide proper earth ground. Figure 2-4 shows the two approved methods for setting up a low-impedance ground.

Installation

PREFERRED METHOD

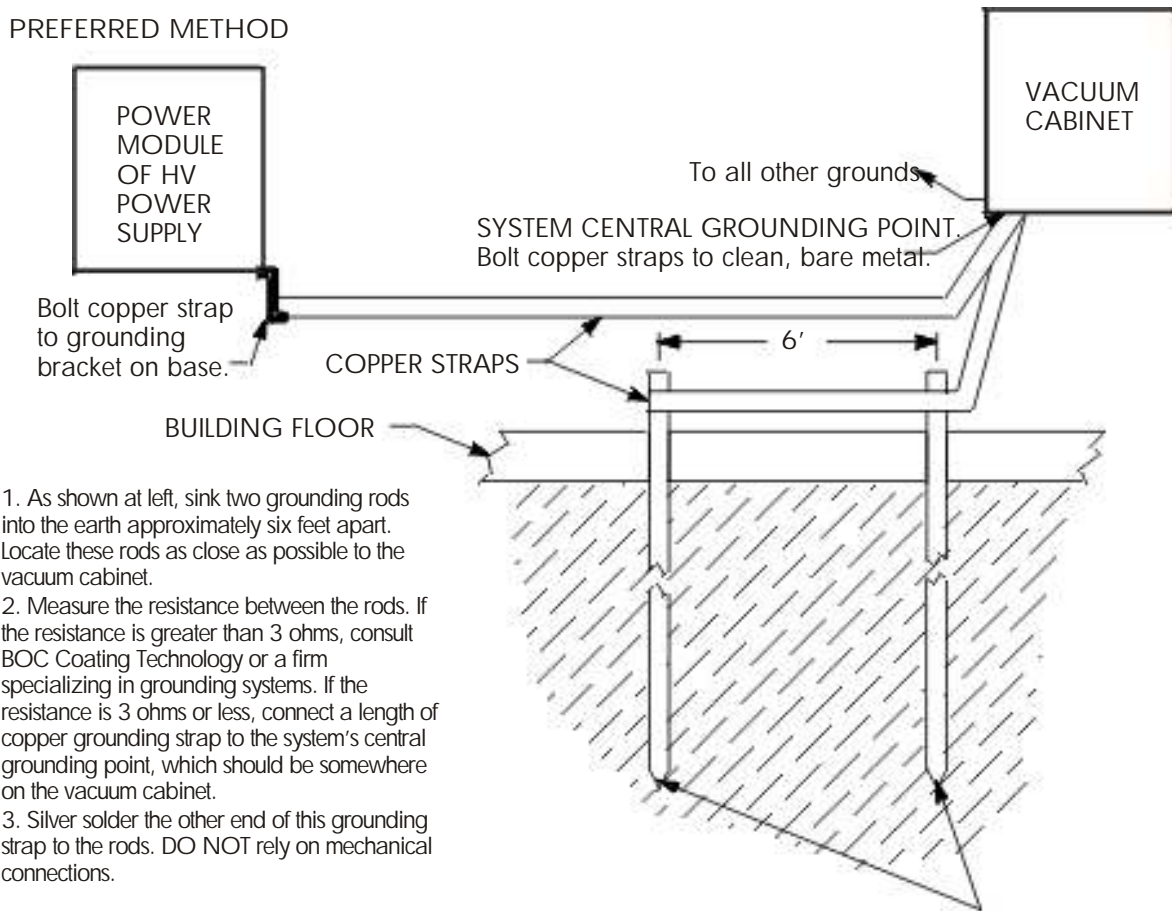

DISTANCE FROM GROUND RODS TO VACUUM CABINET	SIZE OF COPPER GROUNDING STRAP
0-60'	3" wide x .035" to .50" thick
60+'	Consult BOC Coating

GROUNDING RODS, 6' apart.
Copper-clad steel,
 $\frac{3}{4}$ " diameter x 8' long (minimum)

ALTERNATIVE METHOD

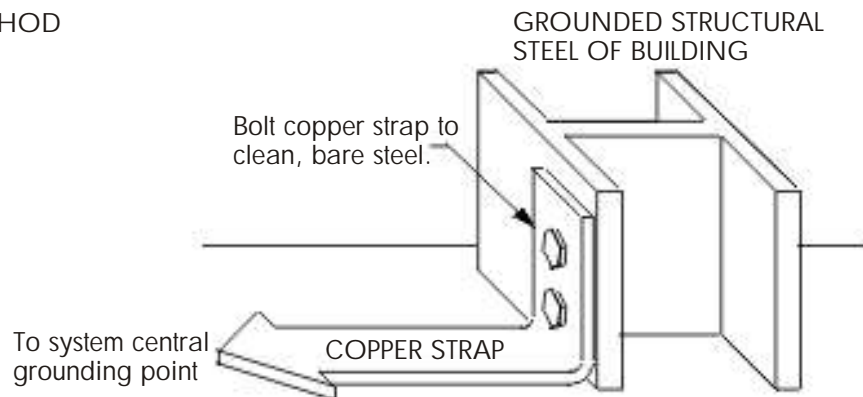

Figure 2-4. Two methods of setting up a low-impedance ground for the vacuum system

2.4 INSTALLING A SECOND SOURCE

If two electron beam sources are to operate on one source tray, they must be installed facing opposite directions. In addition, a mumetal-and-stainless-steel shield assembly must be installed between them to prevent magnetic interference between the two sources. The mumetal-and-stainless-steel shield must not interfere with the operation of the dynamic parts in the PopTop source. Figures 2-5 and 2-6 illustrate two methods of mounting such a shield assembly.

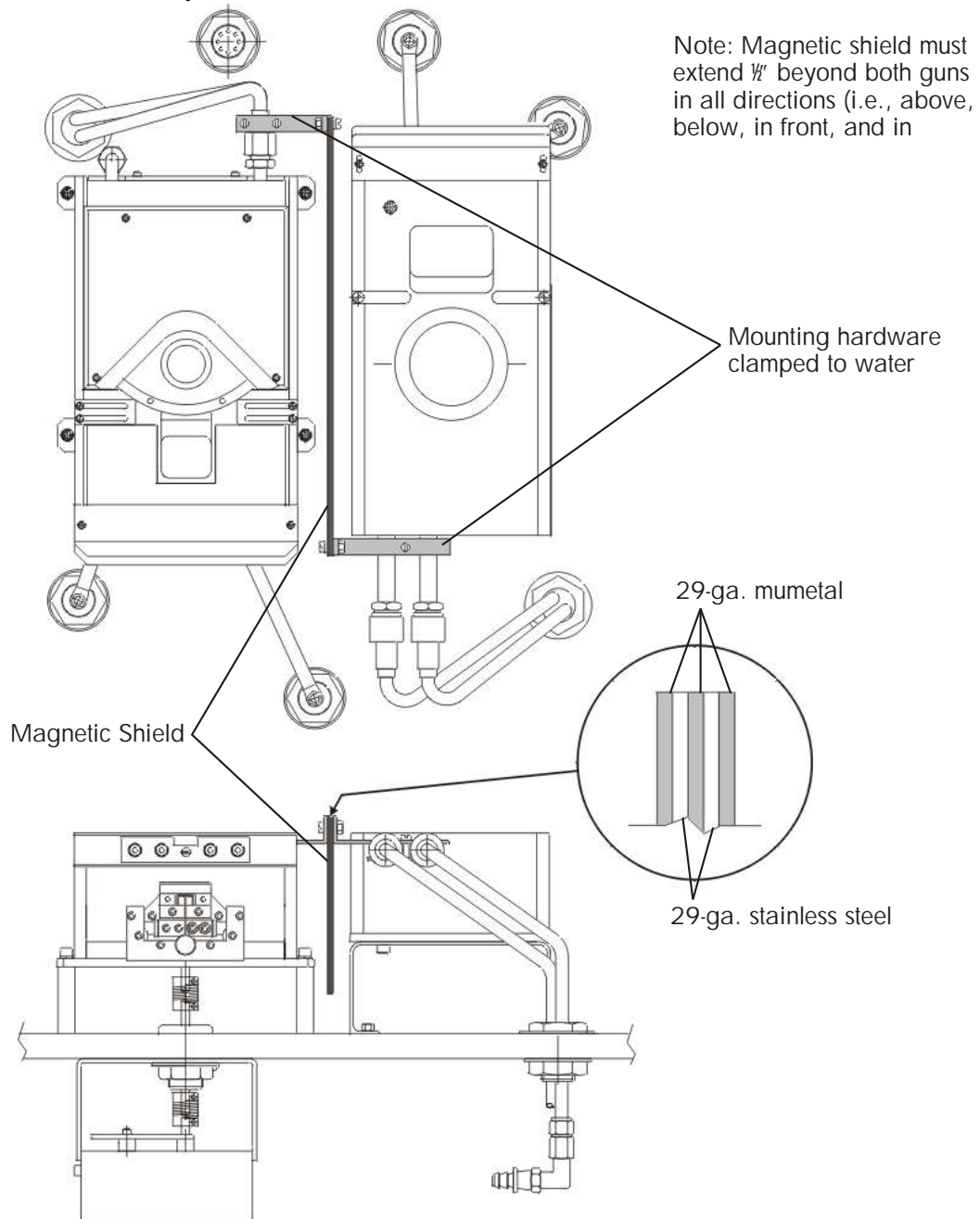

Figure 2-5. Magnetic shield mounted to water lines in two-gun installation

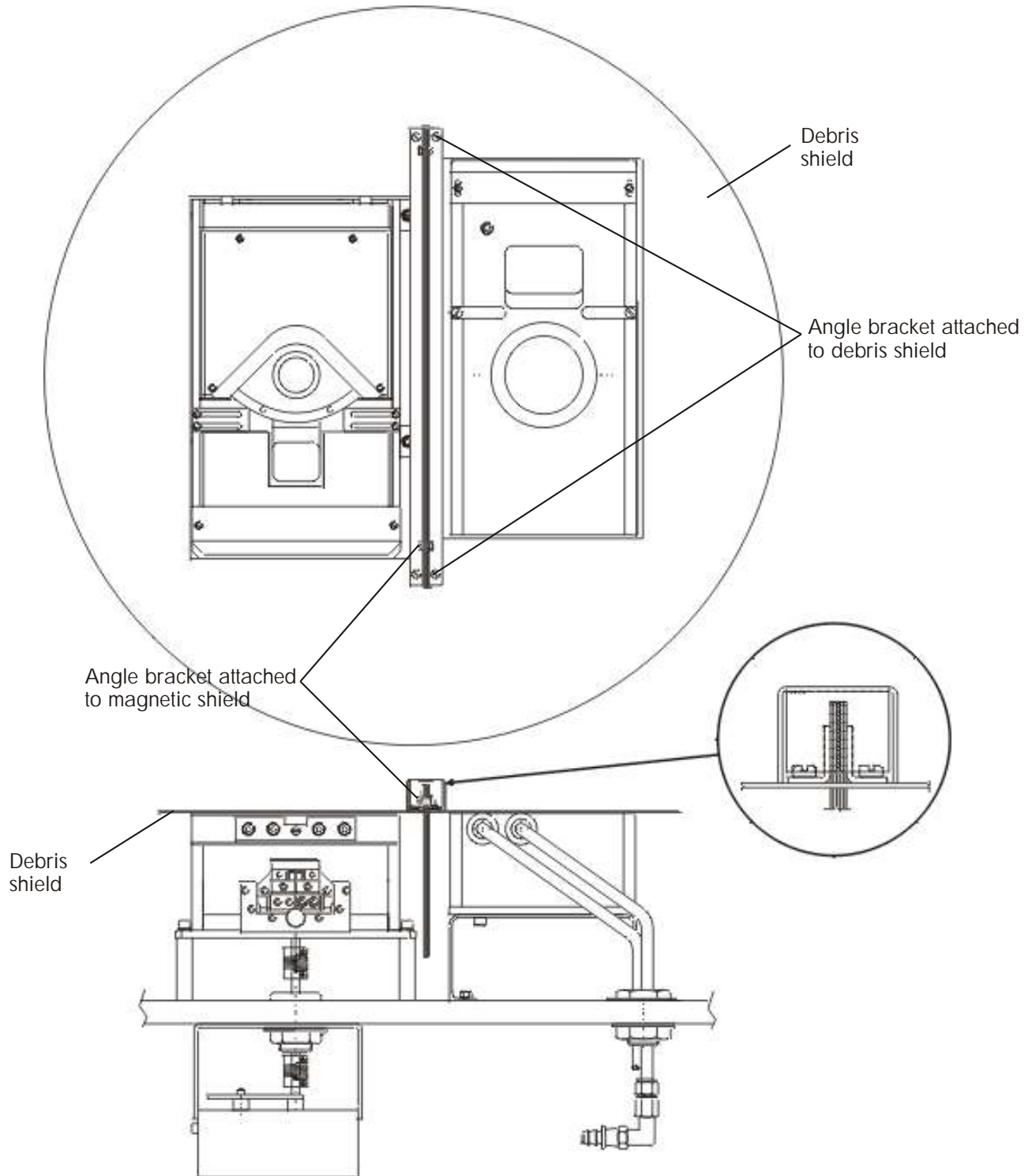

Figure 2-6. Magnetic shield mounted to debris shield in two-gun installation

SECTION 3 OPERATION

3.1 SECTION OVERVIEW

This section provides a guide to source operation. Section 3.2 is an overview of the electron beam controls, section 3.3 describes the initial operating procedure, and section 3.4 describes routine inspection and cleaning procedures. These three subsections are provided as general guidelines to the subjects they cover; actual operating procedures will vary, depending on the details of your installation and application(s). Note, however, that section 3.5 provides specific instructions for removing and replacing the crucible cover and crucible.

Specific technical data on other aspects of electron beam deposition are available upon request from Temescal.

3.2 ELECTRON BEAM CONTROL

The source operates in conjunction with an electron beam power supply and, optionally, with a beam sweep controller. Various features of these components allow control over the following beam parameters:

- total beam power
- the position of the beam spot (i.e., the area where the beam strikes the evaporant material)
- the size and shape of the beam spot.

The features that provide control over these parameters are:

- the acceleration voltage control on the e-beam power supply
- the emission control on the e-beam power supply
- the deflection current control(s), whether on the e-beam power supply or the optional beam sweep controller
- the pole piece extensions on the source itself

The effects of adjusting these control features are described below.

Adjusting the Acceleration Voltage

The potential at which the dc electron beam operates is termed the *acceleration voltage*. This value is set via the e-beam power supply's HV control circuit, which should provide a readout of the acceleration voltage in kV. Together with the emission current control, the acceleration voltage determines total e-beam power. However, the acceleration voltage value must be kept constant, as it strongly affects the longitudinal position of the beam spot. Reducing the acceleration voltage moves the beam spot toward the front of the source (i.e., toward the emitter assembly), while increasing the acceleration voltage moves the beam spot toward the rear of the source. For instructions on setting the acceleration voltage, see the manual for your e-beam power supply.

Although the SuperSource2 can be operated at any acceleration voltage between 4 kV and 10 kV, the permanent magnet is gaussed for operation at a specific acceleration voltage value. On the standard model STIH-270-2PT, the permanent magnet is gaussed so that at 10 kV acceleration voltage, the beam strikes the target material just in front of the rear edge of the exposed pocket. On special versions of this source, the permanent magnet may be gaussed so that at 8 kV or 10 kV acceleration voltage, the beam strikes the material at or near the pocket center. In either case, if the source is operated at an acceleration voltage lower than the designated value, the beam will fall in front of the correct position (i.e., farther toward the front of the source). In that event, it may be necessary to mount one or more magnetic shunt bars to make the beam strike the correct position.

Two shunt bars are supplied with the source, although in some cases additional shunt bars may be required. The mounting positions for the shunt bars is shown in Figure 3-1. Note, however, that the effect of the shunt bars varies depending on whether they are mounted on the front or the rear of the source. Therefore, if multiple shunt bars are required, it is important to add them in the following sequence:

1. Mount the first shunt bar atop the coil shield, as shown in Figure 3-1, using the socket-head screws and nuts supplied with the shunt bars.
2. If additional shunting is required, attach a second shunt bar magnetically to the rear of the source, in the rearward position shown in Figure 3-1.
3. If a third shunt bar is required, mount it above the initial shunt bar. Use the mounting hardware provided to hold both shunt bars in place atop the coil shield.

4. If the beam is still not in the correct position, attach a fourth shunt bar magnetically behind the one already mounted on the rear of the source.

CAUTION

Do NOT attempt to attach a shunt bar magnetically to the front of the source. If you do so, the permanent magnet's field will pull the bar strongly and rapidly toward the pole piece extensions, possibly alternating their position and causing minor finger injuries.

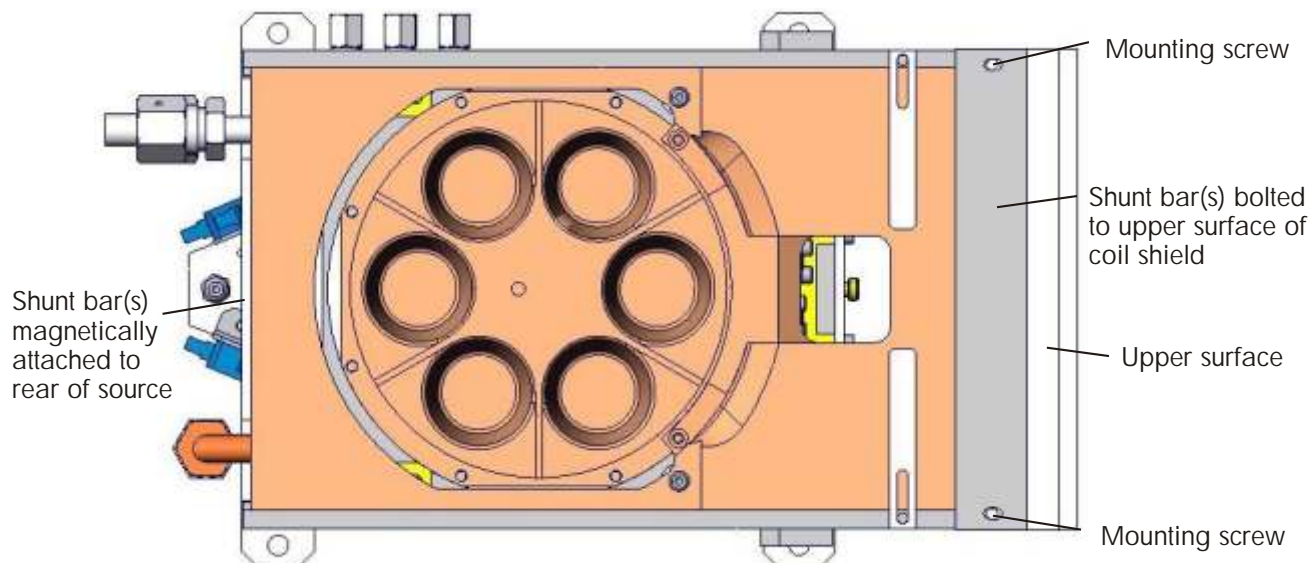

Figure 3-1. Correct mounting location for shunt bar(s)

Adjusting the Emission Current

The *emission current* is the value of the electron beam's high-voltage dc current. Emission current control provides the only means of varying total beam power during a run, as the acceleration voltage value must be kept constant to ensure correct beam positioning. However, this value is not controlled directly but rather by varying the lower-voltage ac current supplied to the gun's filament by the e-beam power supply. The value of this current, which is termed the *gun current* or the *filament current*, is set via the e-beam power supply's gun control circuit. Even if you are adjusting the filament current, an emission current readout should be available on either the HV control panel or the gun control panel of the e-beam power supply.

For instructions on adjusting the emission current, and for a more complete explanation of the relationship between the emission current and the filament current, see the manual for your e-beam power supply.

CAUTION

Never set the emission current so high that the gun's operating-power rating of 10 kW is exceeded. Operating above that power level may result in damage to the crucible or other parts of the source. At 10 kV acceleration voltage, the emission current should be limited to 0.7 A. At 8 kV, the current limit should be 0.875 A.

Adjusting the Deflection Current

A permanent magnet mounted at the rear of the source creates a powerful magnetic field that is the primary force acting on the electron beam. This shape of this magnetic field is modified by the pole pieces that form the sides of the source. The beam's direction can also be affected by operation of the gun's electromagnetic deflection coils. However, with no deflection current applied, the primary magnetic field should keep the beam spot centered laterally, while its longitudinal position is determined by the interaction between the acceleration voltage and the strength of the primary magnetic field along the gun's longitudinal axis.

The deflection coils are contained in a U-shaped metal enclosure mounted in the front of the coil housing. There are two coils for lateral beam-position control and one coil for longitudinal control. Varying the current to these coils affects the position of the beam spot within certain limits. Deflection current control is provided either by the e-beam power supply or by an optional beam sweep controller. The position control on the e-beam power supply allows only manual control over the longitudinal coil current. A beam sweep controller provides either manual or automatic control over the lateral coil current as well as the longitudinal.

For information on using the e-beam power supply to move the beam-spot longitudinally, see the manual provided with the power supply. For instructions on controlling beam-spot position using a beam sweep controller, see the manual for that component.

Adjusting the Position of the Pole Piece Extensions

In addition to the usual external pole pieces, the STIH-270-2PT is equipped with internal pole piece extensions for enhanced control over the size and shape of the beam spot. Adjusting these extensions to alter the size and shape of the beam spot affects beam-spot position and beam uniformity as well as beam density. In general, the beam spot is the smallest, most dense, and most uniform when the pole piece extensions are adjusted all the way in toward the center of the source. As the extensions are adjusted outward, the spot becomes larger, less dense, less uniform. In addition, as the extensions are adjusted outward, the beam spot moves toward the rear of the source and will eventually fall beyond the rear edge of the pocket. If you adjust the pole piece extensions outward to obtain a diffuse beam, it may be possible to bring the beam spot forward to the correct position by either lowering the acceleration voltage or applying longitudinal deflection current, or both. However, if your process calls for a very diffuse beam with the source operating at its design acceleration voltage, keeping the spot in the correct position may require having the permanent magnet regaussing to increase its field strength.

The external pole piece extensions are mounted on top of the source (see Figure 3-2). Adjusting these extensions affects the beam spot most strongly when it is near the rear edge of the pocket. In that area, the beam spot tends to become long and narrow. Moving the external pole piece extensions all the way in minimizes this tendency, shortening the spot without significantly broadening it. Adjusting these extensions outward allows the spot to lengthen.

The internal pole piece extensions extend into the source in the area between the coil shield and the crucible. Adjusting these extensions affects the beam most strongly when it is near the front of the pocket. In that area, the beam tends to assume the shape of a crescent spread laterally around the edge of the pocket. Moving the internal pole piece extensions all the way in minimizes this tendency, compressing the beam spot laterally while chopping off the thin edges of the crescent.

Although the two sets of pole piece extensions affect the beam most strongly at opposite ends of the pocket, each set has some effect on the beam spot at any point in the pocket. For this reason, the two sets of extensions must always be adjusted in tandem. Bear in mind, however, that small movements of the pole piece extensions strongly affect the position of the beam spot as well as its size and shape. As the extensions are adjusted

outward, the beam is deflected farther back toward the rear of the source. Consequently, the pole piece extensions should be adjusted in increments of 1/8" at a time.

To change the position of the external pole piece extensions, loosen the screws that secure the extensions to the source, move them equal distances in the desired direction, and retighten the screws. To change the position of the internal pole piece extensions, first loosen the screws that secure them to their mounting blocks, as indicated in Figure 3-2. (Do NOT loosen the screws that secure the mounting blocks to the sides of the source.) Then move the two extensions equal distances in the desired direction and retighten their mounting screws.

NOTE

The internal pole piece extensions are made with a step in the middle, so that one end of each extension is wider than the other. If you remove these extensions, remember to reinstall them with the step facing UP. Installing the extensions with the step facing down will make the beam broader and more diffuse when it is near to the front of the pocket and reduce beam uniformity regardless of beam-spot position.

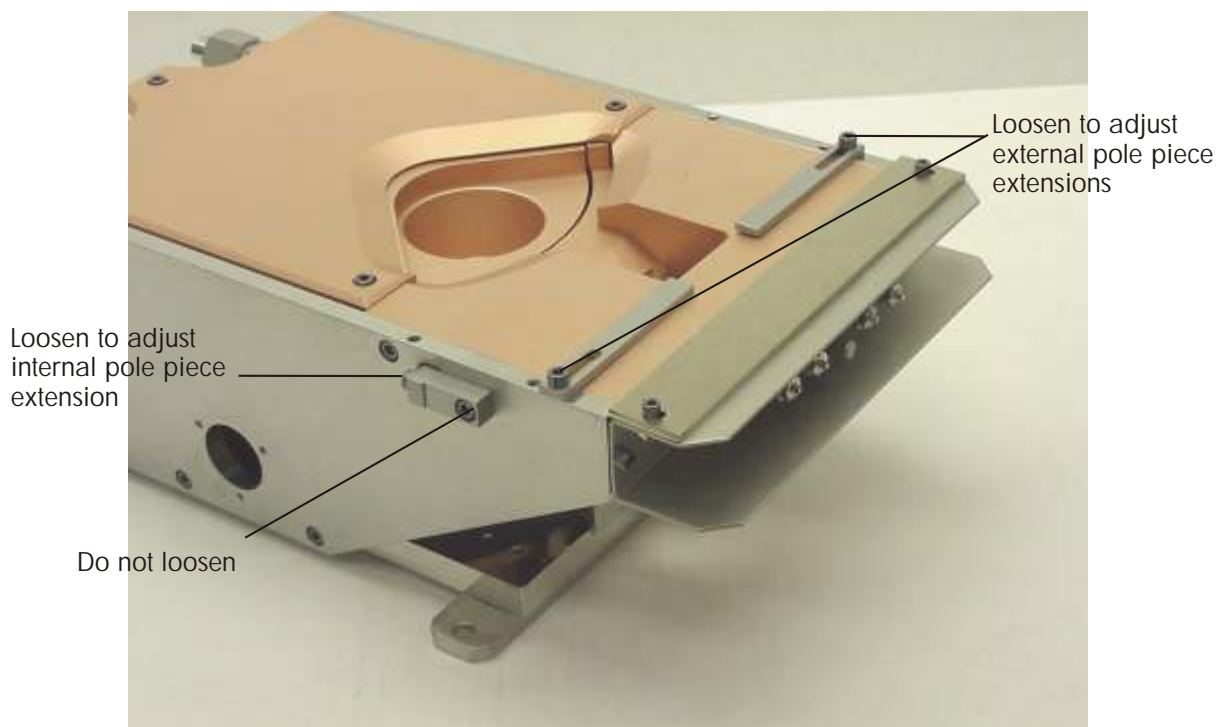

Figure 3-2. Location of the internal and external pole piece extensions

3.3 INITIAL OPERATION

Follow the procedure described below in operating the source for the first time. Before beginning this procedure, make sure that the following conditions are met:

- The source has been installed in accordance with the instructions in Section 2.
- The main circuit breaker on the electron beam power supply is in the OFF position.
- If you are using a beam sweep controller, disable the sweep function, putting the unit in position-control-only mode.

1. With the vacuum chamber at atmosphere, fill the crucibles at least half-way with the material to be evaporated.
2. Continue with the following procedure:
 - (a) Discontinue the air flow to the system and bleed pressure out of the air lines. Connect air to the feed-through using the parts contained in the Air System for PopTop Source, Bill of Material 0627-3010-0. Use Schematic 625-2634. Speed controller valves (Item 62) can be installed anywhere on the tube line if they are easily accessible. The speed controllers should be set 1/4 to 1/3 turn from fully closed. Note at the bottom of the air feedthrough that one of the tubes is very short. This tube is the vent (do not try to install any fittings on this port).

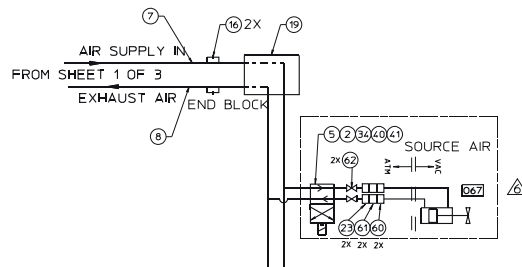

- (b) Add source actuation air solenoids to the air solenoid manifold. Run 1/4" air line solenoid to the 1/8" stainless steel pipe fittings.
- (c) Test source by rotating the crucible manually from the operator's station.
- (d) Raise source tray into sealing position.

CAUTION

Evaporating with a crucible less than half-full may cause damage to the source.

3. Close the vacuum chamber.
4. Switch on the e-beam power supply's main circuit breaker, if it is not already on.
5. Make sure that all of the interlock LEDs on the e-beam power supply—with the possible exception of the position interlock LED—are lit. (The question of the position interlock will be addressed later.) If these LEDs are not lit, take appropriate action to ensure that the interlocks are made. Be particularly certain that the GUN WATER interlock has been made.

6. Evacuate the vacuum chamber to a pressure less than 5×10^{-4} torr.

NOTE

Continuous operation at pressures higher than 5×10^{-4} torr drastically reduces filament life and may result in severe arcing within the chamber.

7. Switch on the high voltage and set the HV control for the desired acceleration voltage.
8. Adjust the longitudinal deflection current so that it will keep the beam spot away from the edge of the pocket. If this current is controlled by either the e-beam power supply or a standard (i.e., non-bipolar) beam sweep controller, adjust the control for that current to .5 A. If the deflection coils are controlled by a bipolar beam sweep controller, set the longitudinal current to 0 A.
9. Check to see whether the position interlock LED is lit. If it is not, then the limits for this interlock are set incorrectly. If you conclude that it is the case, switch off the high voltage and adjust the beam limits. To do so, follow the procedure prescribed in the manual for either the e-beam power supply or the beam sweep controller, depending on which device supplies the signal for the position interlock. Then begin this procedure again from step 1.
10. If the deflection coils are controlled by a beam sweep controller, or if the power supply provides lateral deflection control, set the lateral deflection current to 0 A.
11. Set the emission current control to 0 A.

CAUTION

It is critical to make sure that the emission current is set for 20 mA or less before you switch on the filament current. Failure to do so could result in damage to the source. The safest way to ensure that this is the case is to turn the emission control on the e-beam power supply all the way counterclockwise.

12. Switch on the filament current.
13. Slowly turn up the filament current until the emission current readout indicates 20 mA. Looking at the source through a viewport, you should now see a fluorescence on the surface of the evaporant material. This fluorescence should be somewhere between the center and the rear edge of the pocket. If no fluorescence appears, or if it appears somewhere along the edge of the pocket or on some other part of the source, the limits for the beam position interlock may be set improperly. If you conclude that it is the case, switch off the filament current and the high voltage and perform the procedure for setting the beam limits. (Refer to the manual for either the e-beam power supply or the beam sweep controller, depending on which device supplies the signal for the position interlock.) Then begin this procedure again from step 1.

CAUTION

Do NOT increase the emission current above 20 mA in an attempt to find the beam spot. Doing so may result in serious damage to the source.

14. Adjust the longitudinal deflection current until the fluorescence is centered longitudinally in the pocket. (With no lateral deflection current applied, the beam should automatically be centered laterally in the pocket. If it is not, consult Section 6, Troubleshooting.)

NOTE

If the longitudinal deflection current is controlled by either the e-beam power supply or a standard (i.e., non-bipolar) beam sweep controller, the beam spot should move toward the emitter assembly as you increase the longitudinal deflection current. If increasing the current moves the beam in the opposite direction, the leads to the longitudinal coil are reversed. In that event, switch off the electron beam power supply, disconnect the coil-current cable at the sweep controller, vent the vacuum system to atmosphere, and reverse the wires for the longitudinal current. The easiest place to reverse these wires is at the terminal strip where they connect to the vacuum cubicle's wiring. **DO NOT** operate gun with the longitudinal coil leads improperly connected. Doing so will distort the beam and seriously shorten the lifetime of the permanent magnet. Note that this problem will not arise if you are using a bipolar sweep controller.

15. Once the fluorescence is centered in the pocket, use the position control(s) on either the e-beam power supply or the beam sweep controller to check the position interlock limits. If the source is not controlled by a beam sweep controller, use the power supply's longitudinal position control to slowly run the beam spot from one end of the pocket to the other. At both the front and rear ends, the beam should be extinguished just before it gets to the edge of the copper. If the source is controlled by a sweeper, then check the position interlock limits in both axes. If the limits are not set properly, switch off the high voltage and the filament current and follow the appropriate procedure to set them correctly. Then begin this procedure again from step 1.

CAUTION

If the beam impinges on the edge of the crucible, copper will be evaporated and the run will be contaminated. Serious damage to the crucible will also result if the source is allowed to continue operating with the beam spot in this position.

16. Once you have verified that the position interlock limits have been set correctly, slowly increase the emission current until the beam spot appears in the same area as the fluorescence.
17. If you are using a sweep controller, switch on its sweep function and establish an appropriate pattern. If not, readjust the beam spot's position as desired to optimize the heating and evaporation of the target material. For many materials, evaporation rates can be improved if the beam spot is slightly behind pocket center.
18. Slowly increase the emission current until the desired evaporation level is reached.

Operation from this point on will vary from application to application. If you encounter any problems in operating the source, refer to the troubleshooting procedures in Section 6.

CAUTION

Whenever you prepare to vent the system, allow two to three minutes for the filament and the rest of the emitter assembly to cool first. Exposing a hot filament to atmosphere will cause rapid oxidation and shorten filament life.

3.4 ROUTINE INSPECTION

Inspection Upon Venting

Perform the following checks each time the system is vented to atmosphere.

1. Check to see that each pocket is at least half-full. Add evaporant material as required to maintain the desired pool level.
2. Examine the crucible for residual waste from the previous evaporation run. If left in the crucible, such material can contaminate other evaporant materials, prevent the cover from closing properly, cause thermal shorts, and reduce the evaporation rate.
3. Inspect the cover for excessive evaporant build up. Remove and clean.

NOTE

Make sure the cover is in the up position before trying to remove the attaching screws. Refer to Section 3.5.

4. Look for loose flakes of evaporant and other debris on and around the other parts of the source. Be sure to inspect the area around the emitter assembly, the high-voltage leads, and the high-voltage feedthroughs. Debris and flakes in these regions can cause short circuits. Use an industrial vacuum cleaner to remove any loose material from these areas.

Periodic Inspection

The intervals for this inspection are process dependent, varying with the thickness of the layers deposited, the material used, the source-to-substrate distance, and other factors. The user must therefore set the schedule for this inspection.

1. Perform the checks described above.
2. Check all feedthroughs for fouled components and clean any that are found.
3. Remove the emitter assembly from the source and examine its high-voltage spacing insulators and flanged insulators. (These components can be inspected without disassembling the emitter.)
4. Check the emitter assembly for evaporant buildup. When the buildup begins to look as though it is affecting the emitter's performance, disassemble and clean the emitter.
5. Examine the outer surface of the anode. You need not be concerned about discoloration, but look for any signs of distortion or burning caused by arcing. On high-performance emitters, pay especially close attention to the anode surface just in front of the gap between the two beam formers (see Figure 5-3). If you find any burned spots, replace the anode.
6. Examine the filament as closely as possible without removing it from the emitter assembly. Replace the filament if you observe any of the following conditions:
 - Breaks in the filament.
 - A misaligned filament, which can cause poor emitter performance.
 - Thin spots in the filament, which can cause hot spots in the evaporant.
 - A warped filament, or one that sags in the center, which usually results from operating the source at very high temperatures. A sagging filament will eventually burn the anode.

Operation

- Severe oxidation above the areas where the filament legs contact the filament clamps. Severe oxidation in these areas may indicate that a layer of insulation has formed between the filament and the filament clamps, reducing continuity and emitter efficiency.
7. If you replace the filament, be sure to clean the V-shaped grooves in the filament clamps. Use 400-grit (or finer) emery paper to surface the grooves, as coarser emery or sandpaper can roughen the metal surface enough to cause arcing in the chamber. After using the emery paper, remove residues from these parts by thoroughly cleaning them, either ultrasonically or using isopropyl alcohol.
 8. Once the filament is installed, use an ohmmeter to check the resistance between the two emitter bus bars. If the meter reads infinity or a value significantly greater than 0.3 ohms, replace the filament. A reading of infinity indicates a broken filament. Too-great resistance between the two bus bars confirms that an insulating oxide layer has developed between the filament legs and the contact areas around them.

3.5 CRUCIBLE REMOVAL AND REPLACEMENT

The PopTop SuperSource2 is designed to provide easy access to the crucible and easy crucible removal, all without source disassembly. The removable crucible cover is secured by only three screw, and removing the cover does not necessitate blowing the water out of the source. Crucible removal does require blowing down the source, but once that is done, removing the crucible is a simple matter of removing eight socket-head screws.

Follow the instructions provided below when performing either of these procedures.

Removing the Crucible Cover

Note:

Before loosening the cover screws, all the pressure and force between the cover and the coil housing must be removed. As a result, the potential of galled threads and screw breakage between the mounting screws and push rods is reduced. A backing wrench (to prevent loosening of the spider plate and push rod connection) should be used on the hex portion of the push rods when removing the cover screws.

To remove the cover, command the source to go to Pocket 1. When the rotation is complete, turn the indexer off (the power switch is located on the front panel of the indexer in the operators station), then unplug the power cord from the back to prevent the indexer from being inadvertently turned on. When the indexer is turned off the cover defaults to, and maintains, the raised position. With the cover in the raised position, remove the three mounting screws. The cover needs to be reinstalled in the same raised condition.

Warning:

When the indexer is turned back on, the cover momentarily lowers (closes) and then raises (opens) until communication with the TCS is re-established. To avoid a pinch hazard, precautions should be taken to ensure the indexer is not powered on during cover removal or reinstallation.

Operation

The removable crucible cover of the PopTop SuperSource2 provides quick access to the crucible, making it easy to clean the crucible cover and the upper surfaces of the crucible, or remove the crucible. Follow the procedure described below when removing the cover for any of these reasons.

1. Using the Allen wrench provided with the unit, remove the three socket-head screws that secure the crucible cover to the push rods (see Figure 3-3) and remove the cover. To ensure that the connection between the push rods and spider plate are not inadvertently loosened, use a backing wrench on the push rods.

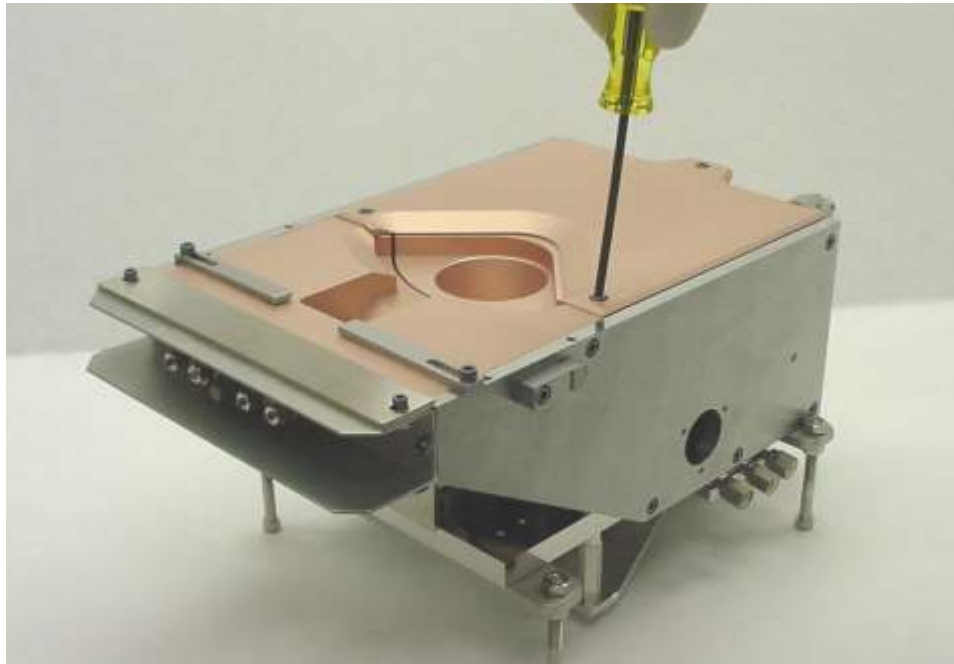

Figure 3-3. Removing the crucible cover

NOTE

The water circuit can remain active while you remove the crucible cover, as cooling water does not flow through the cover.

2. Check the crucible and cover for flakes of debris and excessive evaporant buildup. Pay especially close attention to the barriers between the pockets and to the edge of the cutout in the front of the cover. Build-up along these surfaces can impede proper seating of the cover to the coil housing during operation. Remove any buildup from the edge of the cover's cutout, or, if you have a clean cover on hand, replace the cover and set the used one aside for thorough cleaning and glass-bead honing. If the cover has become warped or has rough surfaces, smooth and straighten. Clean the buildup on the crucible's barriers as thoroughly as possible without risking contamination of the material in the pockets.

Removing the Crucible

The PopTop SuperSource2 enables you to remove the crucible without extensive source disassembly, making it easy to clean the crucible thoroughly, switch crucibles, or check the condition of the O-ring in the crucible mounting flange. Follow the procedure described below when removing the crucible for any of these reasons.

1. Remove the crucible cover, following the procedure described above.
2. Turn off the water flow to the source.
3. Shut off the inlet water supply and apply compressed air to the inlet to blow the remaining water out of the source. If your system has a pressurized return line, the air line you connect should have a check valve to prevent water from entering the air line. For best results, shut off the water supply to the return line just before shutting down the compressed air.
4. Now you are ready to remove the screws that secure the crucible to the crucible mounting flange. To do so, use the special Allen tool provided with the source. This tool consists of a standard $7/64$ " Allen driver with a machined sleeve fitted over its shaft (see Figure 3-4). If you are not experienced using this tool, perform step 5 of this procedure. If you are already proficient at using the tool, skip step 5 and proceed to step 6.

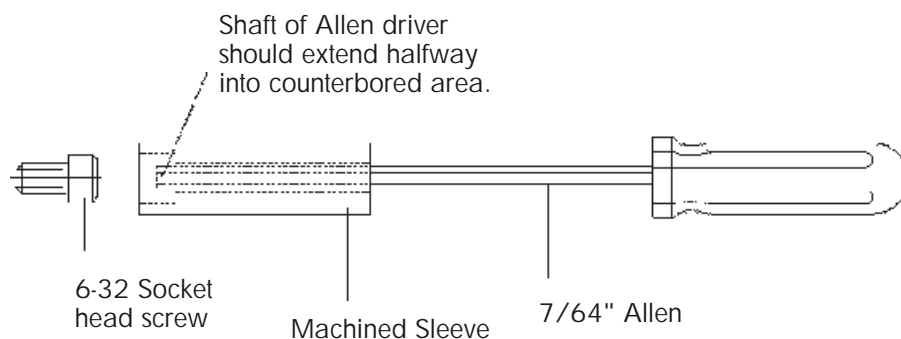

Figure 3-4. Correct arrangement of sleeve on shaft of Allen driver

5. Screw one of the screws you removed from the crucible cover back into one of the holes in the coil housing. Using the special Allen tool, practice inserting the end of the tool into the hexagonal socket in the end of the screw while ensuring that the sleeve extends down far enough over the screw's head so that the screw is held securely by the sleeve after the screw is removed from its threaded hole (see Figure 3-5).

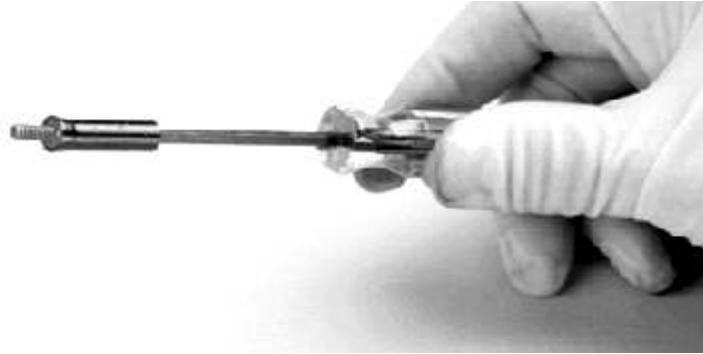

Figure 3-5. Socket-head screw correctly retained by sleeve on end of Allen driver

6. Remove the screws securing the crucible to its mounting flange. There are eight of these screws, and six of them will be accessible if you turn the crucible to the position shown in Figure 3-6. Perform the following steps in removing these screws:

CAUTION

It is important to follow the procedure described below in removing the crucible mounting screws. The compressed O-ring exerts considerable upward force against the crucible, and the counter-pressure exerted by the mounting screws must be relieved evenly to prevent damage to the screws or the threads in the crucible mounting flange.

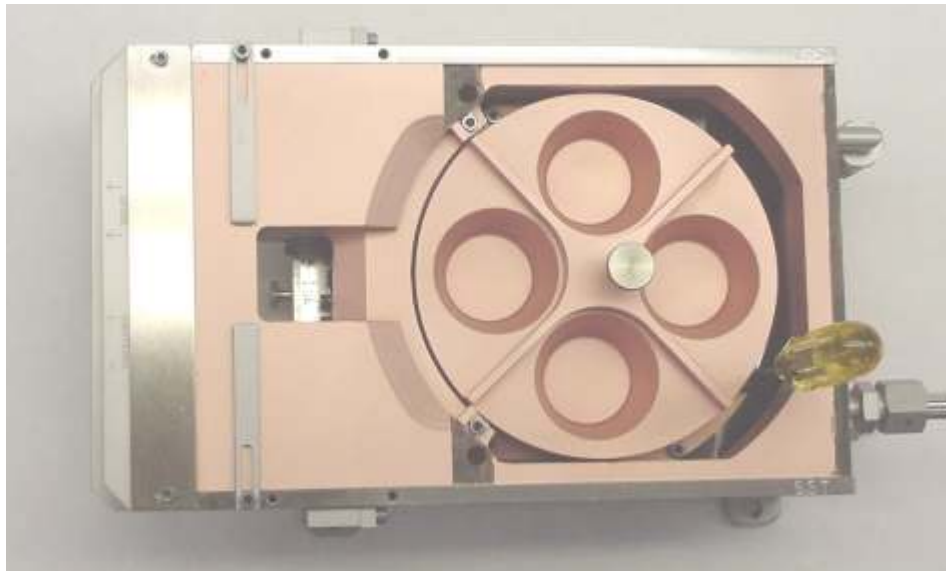

Figure 3-6. Removing the screws that secure the crucible to the crucible mounting flange

- (a) Remove the two screws in the back of the crucible.
 - (b) Rotate the crucible 180° and loosen the six remaining screws ½ turn, beginning with the two screws that are now in the rearmost position.
 - (c) Remove these six screws, beginning with the two in the rearmost position.
7. Screw the knurled thumbscrew into the tapped hole provided for it in the top of the crucible. Then rotate the crucible so that the off-center thumbscrew is toward the rear of the source, as shown in Figure 3-7.

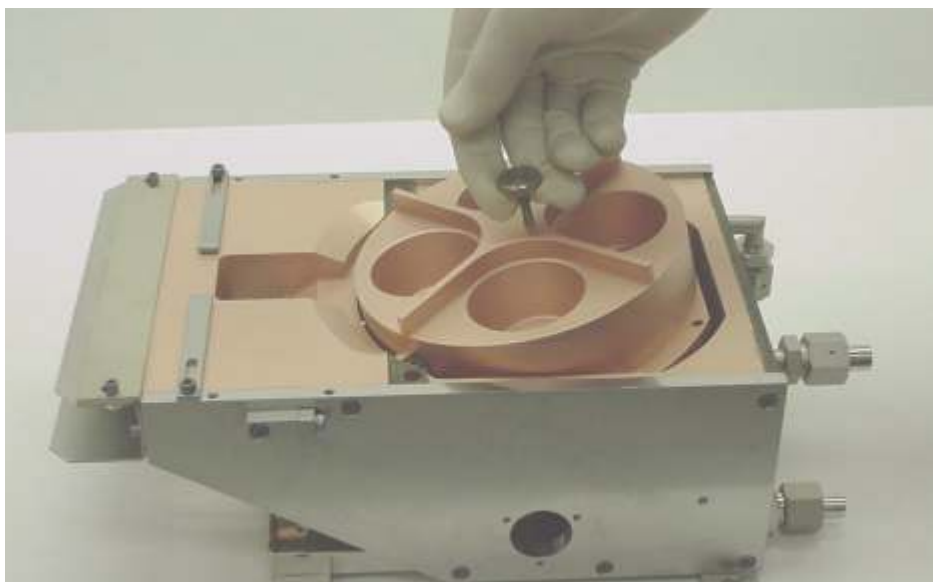

Figure 3-7. Source with crucible cover removed and knurled thumbscrew in place in top of the crucible

8. Remove the crucible from the source, following the steps described below to avoid damaging the O-ring-sealing surface on the base of the crucible. If scraped against the stainless steel water baffle protruding beneath the exposed pocket, this surface can easily be scratched deeply enough that the O-ring in the crucible mounting flange will no longer seal correctly.
- (a) Grasp the knurled thumbscrew and use it to lift the crucible straight up as far as it will go.
 - (b) Raise rear edge of the crucible until it just clears the surface of the coil housing just behind the crucible.
 - (c) Pull the crucible clear of the coil housing by angling it upward and backward at the same time, as shown in Figure 3-8. Be very careful at this point not to scrape the crucible's O-ring-sealing surface on the water baffle.

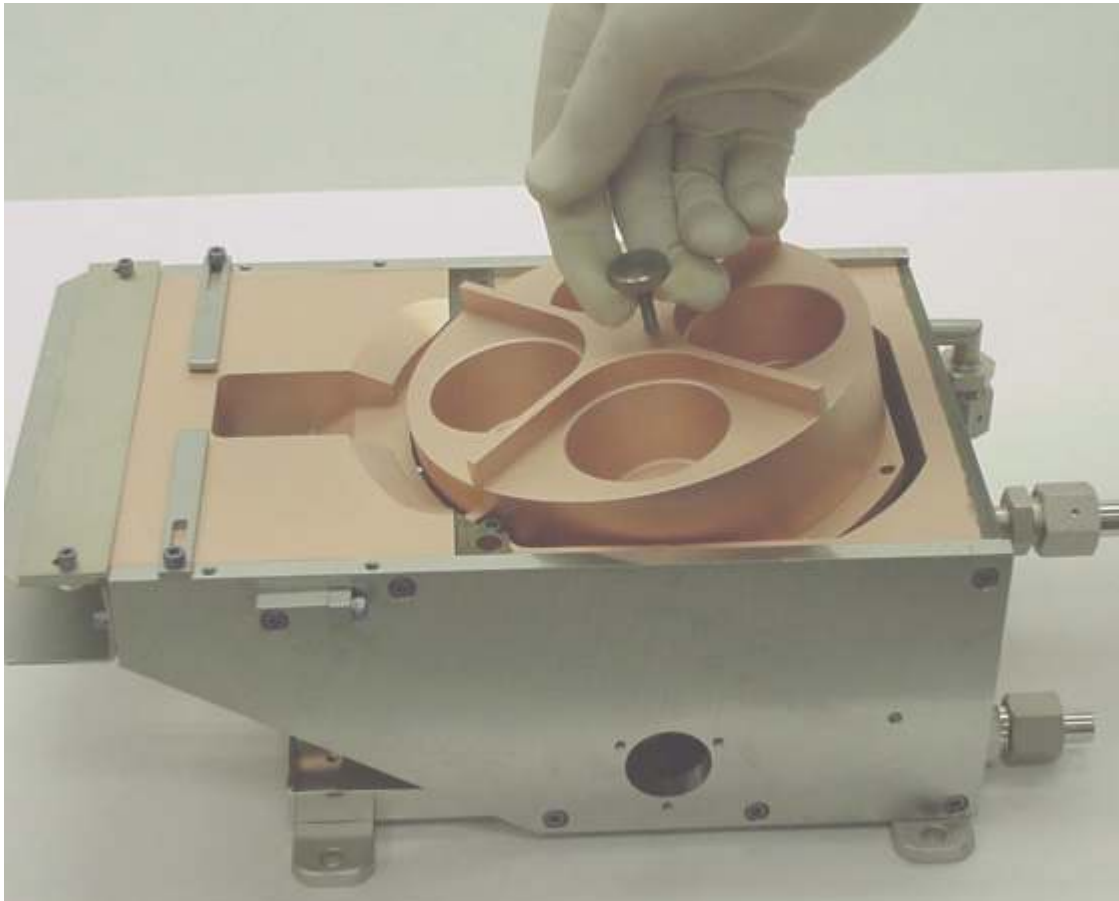

Figure 3-8. Removing the crucible from the source. Note angle of withdrawal

Crucible Replacement

Perform the steps described below when installing a new crucible or reinstalling the same crucible. Be sure to follow the correct procedure when placing the crucible into the crucible well and lowering it onto the crucible mounting flange. It is also critical to follow the correct procedures when replacing the crucible mounting screws. In particular, avoid dropping screws down into the source, as it may not be possible to retrieve them without disassembling the source further. For best results, make sure each screw is held by the special Allen tool as shown in Figure 3-5 before attempting to insert the screw in place.

1. Make sure the crucible mounting flange is in a position that allows you to see six of the eight screw holes.
2. Angle the crucible into the position shown in Figure 3-8. Then lower its rear end so that its bottom surface is horizontal, and lower it straight down onto the O-ring.

CAUTION

Be careful not to scrape the underside of the crucible against the stainless steel water baffle, as doing so may damage the O-ring-sealing surface on the bottom of the crucible.

3. Rotate the crucible until all six threaded holes are visible through the holes in the crucible's base.
4. Insert screws into the six accessible holes and screw them down enough to partially compress the O-ring. As you do so, work your way around the periphery of the crucible in a star-shaped pattern, tightening all sides evenly and gradually.
5. Rotate the crucible so that the other two screw holes are visible, insert screws into them, and tightening them about the same amount as you have already tightened the other six screws.
6. Working your way around the crucible in a star-shaped pattern, continue tightening the screws in two more stages, until you can tell that the O-ring is completely compressed.
7. Replace the crucible cover.

SECTION 4

MAINTENANCE OF HIGH-PERFORMANCE EMITTER ASSEMBLY

4.1 SECTION OVERVIEW

This section describes the procedures involved in proper maintenance of the high-performance emitter assembly. Section 5.2 describes how to change the filament, section 5.3 details the disassembly procedure for the entire emitter, and section 5.4 covers emitter reassembly.

General Precautions

- 1 To minimize contamination, always wear rubber surgical gloves or other particulate-free gloves when handling parts that will not be chemically cleaned before being installed in the vacuum chamber.
- 2 Examine all screws as you disassemble the emitter and replace any that show signs of thread damage or distortion. Damaged screws are likely to become frozen in place during subsequent source operation, resulting in breakage or thread stripping the next time you attempt to remove them. Coat all screws that you do reuse with molybdenum disulfide (ROCOL or equivalent). When replacing screws, use only stainless steel 6-32 socket-head screws of the correct lengths (see Figure 4-3). All screws must be vented so as to create a path through which gases trapped between the threads can be pumped out. To minimize virtual leaks, it is important that the underside of the screw's head as well as its threads be vented. For best results, use the screws that are available from Temescal, as they come machine vented in the correct manner.

4.2 FILAMENT REPLACEMENT

Follow the procedure described below in changing the filament, referring as needed to the illustrations in this section.

1. Switch off the e-beam power supply's main circuit breaker.
2. If the high-voltage control on the power supply is keylocked, remove the key and keep it with you until you have finished working on the source.
3. If this gun's deflection coils are controlled by a Temescal Programmable Sweep, unplug that unit's input power cable. If the gun's deflection coils are controlled by a beam sweep controller with a power on/off switch, switch off the power.
4. Touch a properly connected grounding hook to the high-voltage components in the vacuum cubicle to remove any residual high-voltage charges. Leave the grounding hook in place across the secondary of the gun filament transformer while you are working in the vacuum cubicle.
5. Vent the system to atmosphere.
6. After waiting three minutes for the emitter to cool down, open the work chamber and perform whatever procedures are required to gain full access to the source. On Temescal systems, this will entail lowering the source tray and swinging it out from the system.
7. Disconnect the high-voltage leads from either the filament bus bars or the high-voltage feedthroughs.
8. Remove the knurled thumbnut that secures the emitter assembly to the gun's baseplate.
9. Pull the emitter straight out from the source.
10. Working now at a bench, remove the two screws that secure the filament clamps to the cathode blocks.
11. Remove the old filament, using tweezers if necessary. Check for traces of broken filament material on the filament clamps and in and around the filament cavity.
12. Check to see that the V-shaped grooves in the filament clamps are clean and smooth. If they are not, surface them with 400-grit (or finer) emery paper. Also check the front surface of the cathode blocks for signs of oxidation and clean that surface with emery paper as necessary.
13. Remove all residues from the parts you have surfaced with the emery paper. Clean these parts either ultrasonically or by applying isopropyl alcohol.
14. Place the new filament in the filament cavity, with the coil of the filament facing toward the front edge of the beam formers.

CAUTION

The filament MUST be installed with the coil facing forward (i.e., toward the front edge of the beam formers).

CAUTION

Do not handle the new filament with your bare hands. Salt and oil from the skin will shorten filament life.

15. The spare parts kit (PN 0916-8300-0) for the high-performance emitter provides a filament alignment rod (PN 0916-8271-0). This tool is designed to ensure that the filament is positioned and aligned correctly before the clamp screws are tightened. Insert the alignment rod through the hole in the end of one cathode block, through the filament's coils, and into other cathode block. The rod should pass smoothly through the filament's coils and hold it securely in place.
16. Put the filament clamps in place and loosely install the screws that secure them to the cathode blocks. Before tightening these screws, make sure that the filament legs are located squarely in the V-grooves in the filament clamps and that there is no binding between the alignment rod and the filament's coils.
17. When you are sure that the filament is in the correct position and not binding against the alignment rod, tighten the filament clamp screws.
18. Carefully withdraw the filament alignment rod. If it binds against the filament's coil as it is withdrawn, slide it back into place, loosen the filament clamp screws and readjust the filament's position until the rod can be withdrawn without any binding. When you have finished using the alignment rod, return it to the spares kit.
19. Use an ohmmeter to check the continuity between the filament clamps. The meter should show little or no resistance (i.e., not more than 0.3 ohms) between the clamps. If the meter indicates infinite resistance, the filament has been broken during installation and must be replaced. In that event, remove the filament and repeat steps 15-18 of this procedure. Then test the continuity again. If the ohmmeter reads something significantly greater than 0.3 ohms but less than infinity, the filament legs may not be making good electrical contact with the filament clamps. Try loosening and then retightening the filament clamp screws, paying particular attention to the instructions in steps 16-18 regarding the position and alignment of the filament. Then repeat the continuity check.
20. Put the emitter assembly in place in the source. Before tightening the knurled thumbnut, make sure that the emitter assembly is snug against the front of the base plate. When the emitter assembly is correctly positioned, the front of the anode should line up with the opening in the coil housing through which the beam passes.
21. Reconnect the filament leads.

If the source fails to operate properly after the emitter is reinstalled, it may be because various components have oxidized, eroded, or become coated with evaporants to such a degree that cleaning is necessary. Refer to section 3.4 for source cleaning procedures.

4.3 EMITTER DISASSEMBLY

Follow the procedure described below when disassembling the entire emitter assembly. Refer to Figures 5-1, 5-2, and 5-3 for parts identification.

1. Perform steps 1 through 12 of the filament replacement procedure (see section 5.2).
2. Working now at a bench, remove the two screws that secure the anode mounting bracket to the emitter support bar. Then remove the anode mounting bracket and the anode from rest of the emitter assembly.
3. Remove the two screws that secure the anode to its mounting bracket.
4. Check the anode for signs of burning or distortion. If any are found, replace the anode.
5. Remove the two screws that secure to right- and left-hand beam formers to the right- and left-hand cathode blocks, respectively, and remove the beam formers.
6. Remove the four screws that secure the filament bus bars, the cathode blocks, and the cathode block insulator to the emitter mounting bar.
7. Remove the two screws that secure the emitter mounting bar to the two high-voltage spacing insulators and remove the emitter mounting bar.
8. Remove the two screws that secure the high-voltage spacing insulators to the emitter support bar. Doing this will allow you to remove the spacing insulators and their shields.
9. Remove the two screws that secure the emitter mounting bracket to the emitter support bar.
10. Carefully examine all metal parts for signs of erosion and deformation and replace any that show such signs of wear. Even rounding of originally square edges can complicate reassembly and adversely affect emitter performance. Before reassembly, bead-blast and chemically clean all reusable parts of the emitter.

4.4 EMITTER REASSEMBLY

Follow the sequence described below when reassembling the emitter. Refer to Figures 5-1, 5-2, and 5-3 for parts identification. It is advisable to use new ceramic parts when reassembling the emitter. It is extremely difficult to clean these parts thoroughly, and they are likely to have invisible cracks that can result in breakage upon reassembly and/or shorts during subsequent source operation.

During the reassembly procedure, pay close attention to screw lengths, which are 1/4" throughout, except for:

- the two 1/2" screws that secure the right-hand filament bus bar and cathode block to the mounting bar
- the two 3/8" screws that secure the left-hand filament bus bar and cathode block to the mounting bar
- the two 3/8" screws that secure the HV spacing insulators and their shields to the emitter support bar
- the two 3/8" screws that secure the emitter mounting bar to the HV spacing insulators.

During reassembly, use a torque driver capable of good resolution in the 4 in.-lb. to 8 in.-lb. range. Torque all screws that secure metal to metal to 8 in.-lbs. Before assembling metal parts to ceramic parts, examine the metal parts to make sure that they are flat, true, and free of burrs and other raised defects. Torque all screws that secure metal parts to ceramic parts to 4 in.-lbs. As you do so, pay close attention to the ceramic parts to see whether they crack and replace any that do develop cracks.

1. Lay the emitter mounting bar flat on your work surface.
2. Put the left-hand cathode block in place on the emitter mounting bar.
3. Put the left-hand filament bus bar in place atop the left-hand cathode block.
4. Install and tighten the 3/8"-long screws that attach the left-hand filament bus bar and cathode block to the mounting bar.
5. Put the cathode block insulator in place on the emitter mounting bar. Figure 4-4 indicates the insulator's correct position, with its top tab facing rearward and its holes aligned with the two right-hand holes in the emitter mounting bar.
6. Put the right-hand cathode block in place on top of the cathode block insulator.
7. Place the right-hand filament bus bar in position atop the right-hand cathode block.
8. Insert the flanged insulators through the holes in the right-hand bus bar and cathode block.

CAUTION

The flanged insulators and the cathode block insulator MUST separate the right-hand cathode block from the emitter mounting bar. If they do not, there will be a dead short between the two filament bus bars when power is applied, and no emission will be obtained.

9. Put the washers in place on the 1/2"-long screws that secure the right-hand filament bus bar and cathode block to the emitter mounting bar. Then install these screws, leaving them slightly loose.
10. Check to see that the two cathode blocks are aligned vertically and are not cocked with respect to each other or the emitter mounting bar. Then tighten the screws that secure the right-hand filament bus bar and cathode block to the emitter mounting bar.
11. Reinstall the right- and left-hand beam formers, leaving their mounting screws slightly loose.

Maintenance of High-Performance Emitter Assembly

12. The spares kit (PN 0916-8300-0) for the high-performance emitter contains a thickness gauge (PN 0916-8281-0) designed to ensure that the two beam formers are positioned correctly with respect to each other. Insert the blade of this spacing gauge between the beam formers.
13. Push the two beam formers against the gauge with the thumb and forefinger of one hand while using the other hand to tighten the screws that secure the beam formers to the cathode blocks. Doing this will ensure that there is the correct 0.010" clearance between the beam formers.
14. Carefully remove the spacing gauge from between the beam formers and return it to the spares kit.
15. Perform steps 14 through 19 of the filament replacement procedure (see section 5.2).
16. Place the HV spacing insulators inside their shields and reattach them to the emitter support bar, with the closed ends of the shields facing the emitter support bar. Use the remaining two 3/8"-long screws to attach these parts.
17. Reattach the emitter mounting bar to the other end of the HV spacing insulators.
18. Reattach the emitter mounting bracket to the emitter support bar.
19. Reattach the anode to its mounting bracket.
20. Reattach the anode mounting bracket to the emitter support bar.
21. Look into the gap between the forward-facing surfaces of the beam formers and the anode to verify that this gap varies by no more than 0.010". Then check the parallelism of the bottom edges of these surfaces. To do so, hold the emitter with the bus bars facing you and slightly upturned, so that you can just see the edges of the two beam formers beneath the front edge of the anode. The visible edge of the beam formers should be parallel to the bottom edge of the anode to within 0.010". If you find that either of these spatial relationships is out of tolerance by more than 0.010", loosen the screws securing the anode to the anode mounting bracket and adjust the position of the anode. If adjusting the anode's position does not bring these parts within the specified tolerances, at least one of them probably need to be replaced. Remove the anode and both beam formers and carefully examine them for distortion to determine which needs to be replaced.
22. Put the emitter assembly in place in the source. Before tightening the knurled thumbnut, make sure that the emitter assembly is snug against the front of the base plate. The anode plate of the emitter assembly should line up with the opening in the coil housing through which the beam arcs toward the crucible.
23. Reconnect the filament leads.

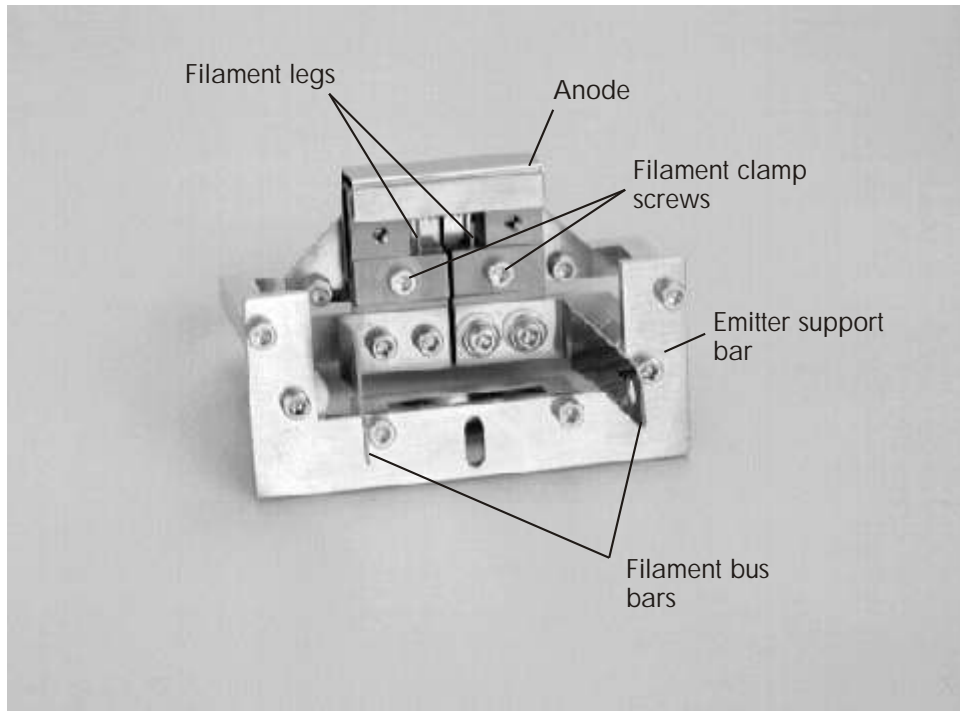

Figure 4-1. Front view of high-performance emitter assembly

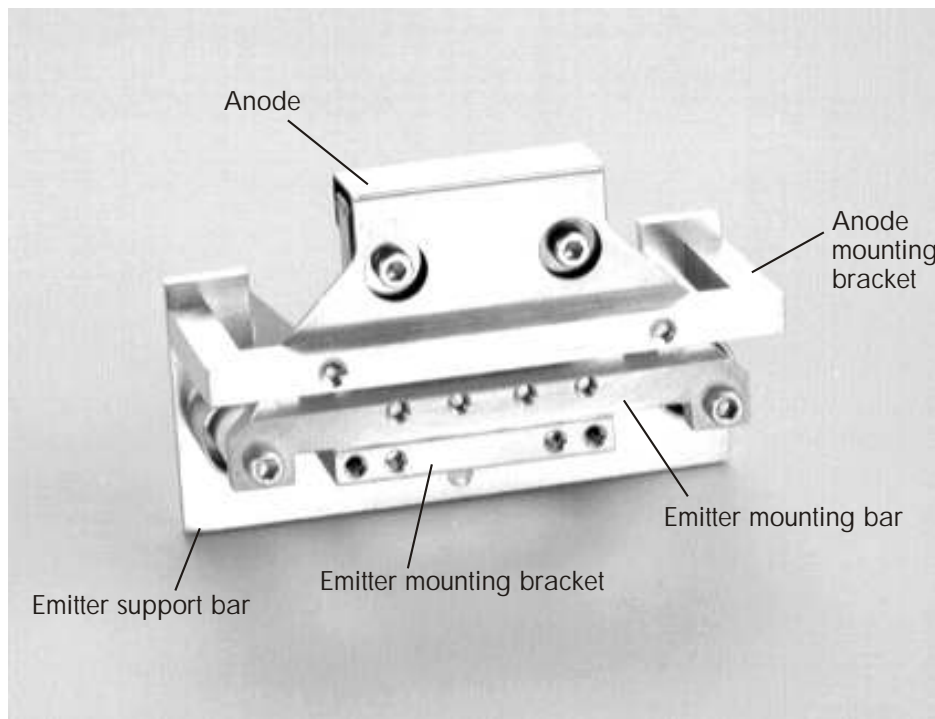

Figure 4-2. High-performance emitter viewed from rear

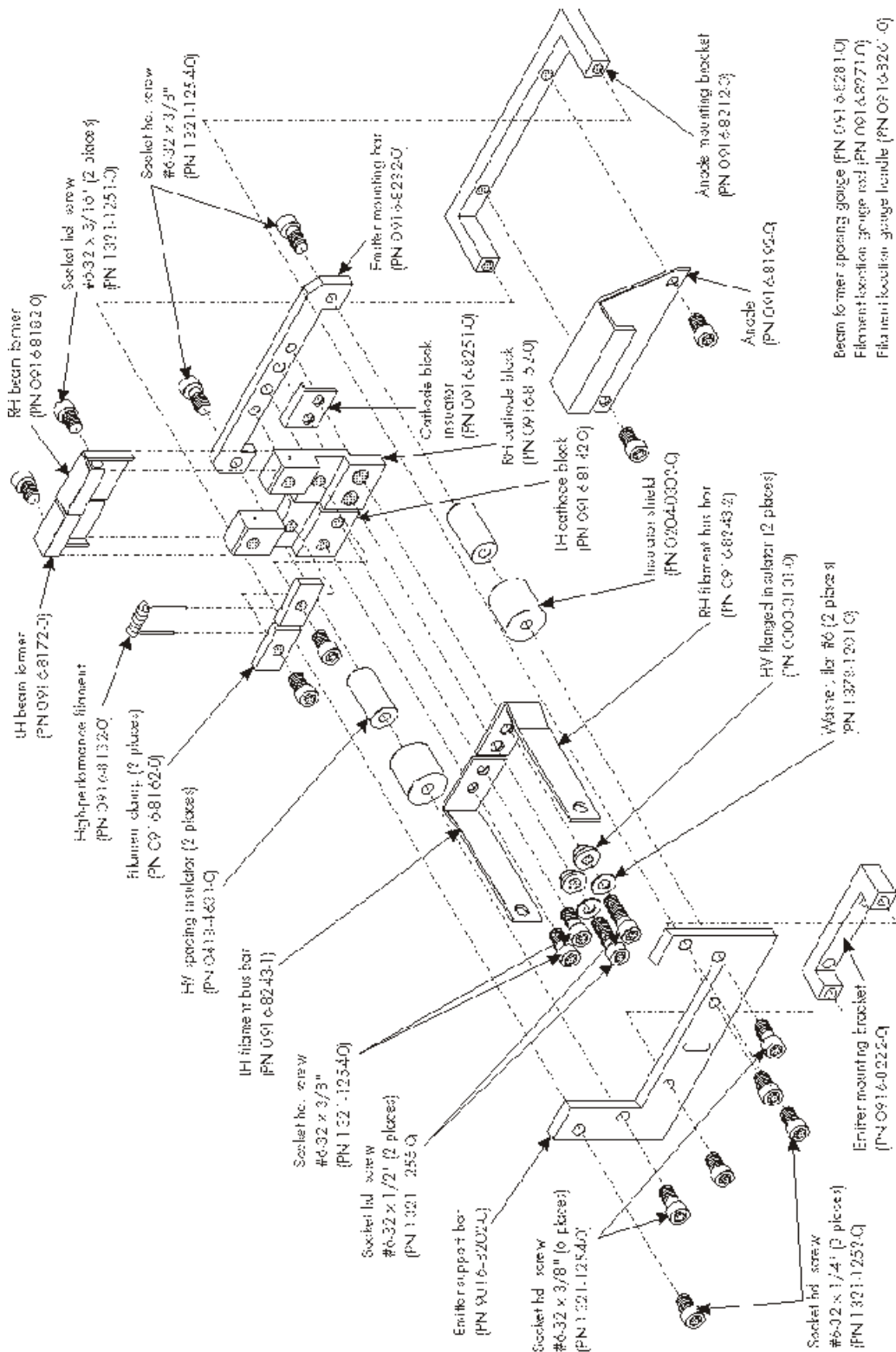

Figure 4-3. Exploded view of high-performance emitter

SECTION 5

SOURCE DISASSEMBLY

5.1 SECTION OVERVIEW

This section describes in detail the correct procedure for disassembling the source. The procedures described in this section should be followed whenever the source is partially or completely disassembled for cleaning or for replacement of O-rings or other parts. Section 5.2 provides general working guidelines and describes the procedures for removing the source from the vacuum system and disassembling its major components, leaving only the emitter assembly, the bearing housing assembly, and the drive assembly still intact. Section 5.3 describes how the bearing housing assembly is disassembled, and Section 5.4 provides the same information for the drive assembly. Disassembly instructions for the high-performance emitter appear in Section 5.

5.2 SOURCE REMOVAL AND DISASSEMBLY

General Guidelines

Follow the guidelines described below when performing any disassembly procedure. The purpose of these guidelines is to limit risks to the person performing the disassembly, to minimize vacuum system contamination, and to simplify reassembly wherever possible.

- 1 Make sure the electron beam power supply is switched OFF. If the power supply is on its own keylocked circuit, open the circuit breaker at the service panel and lock it out. If not, switch off the power supply with its keylock, if it is equipped with one, and keep the key in your possession while working on the source.
- 2 Use a properly connected grounding hook to discharge any residual high-voltage charge in and about the vacuum cabinet. Components that should be discharged with a grounding hook include the filament transformer, the high-voltage feedthroughs, and the in-vacuum high-voltage leads.
- 3 To minimize system contamination, wear some form of lint-free head covering and rubber surgical gloves when removing the source from the vacuum chamber. During the actual source disassembly process, wear the rubber gloves when handling any parts that will not be chemically cleaned before reinstallation.

Removing the Source from the Vacuum Chamber

Follow the procedure described below in disconnecting power and water from the source and removing it from the vacuum chamber.

- 1 Touch the grounding hook to the high-voltage feedthroughs, if you have not done so immediately previous to beginning this procedure.
- 2 Remove the shielding from the in-vacuum high-voltage leads.
- 3 Touch the grounding hook to these high-voltage leads.
- 4 Remove the debris shields, if the system is equipped with them.
- 5 Disconnect the high-voltage leads from the source's emitter bus bars.
- 6 Disconnect the deflection coil leads from the source's deflection coil terminals.
- 7 Switch off the source's water supply.
- 8 Disconnect the water supply and outlet lines at some point outside the vacuum chamber.
- 9 Connect a compressed-air line to the water supply line you just disconnected and use compressed air to blow the water out of the source.
- 10 Disconnect the water supply and outlet lines from the source.
- 11 Turn off the pop top source's air supply and safely release any compressed air left in the lines.
- 12 Disconnect the air supply, return and vent VCR lines from the source.
- 13 Disconnect the external rotary drive to the source. If the source is a bottom drive unit, disconnect the source's drive shaft from the rotary feedthrough in the source tray. If this is a side-drive unit, disconnect the gun's drive shaft from the coupling that connects it to the drive shaft from the rotary feedthrough in the side of the chamber.
- 14 Remove the bolts that secure the source's mounting straps to the source tray.

- 15 Remove the source from the source tray and place it on a suitable work bench. Do not place the source on the bench without first turning it on its side or having supports (1/4-20 screws are adequate) which keep the source's weight off the spider plate. Having the bottom of the spider plate support the weight of the source fully collapses the welded bellows, which under repeated compression may reduce the bellows service life.

CAUTION

If the pneumatic cylinder and spider plate are removed, ensure that the drive shaft does not bump or rest against any hard surface. The shaft's ball bearings are very likely to be damaged by any impact or by the weight of the source resting on the shaft.

Disassembling the Major Portion of the Source

The following procedure describes how the source is disassembled to the point shown in Figure 5-15. At that stage, the only subassemblies left intact will be the emitter assembly, the bearing housing assembly, pneumatic cylinder, and the drive assembly. Sections 5.3 and 5.4 describe the disassembly of the bearing housing assembly and the drive assembly, respectively.

In general, it is best to avoid disassembling anything that does not have to be disassembled. In particular, avoid removing the magnet stops and pneumatic cylinder from the source's base plate or the ring gear from the crucible mounting flange unless it is absolutely essential, as realignment of these parts is somewhat involved. The slotted magnet stops can only be replaced accurately if you put the permanent magnet in place beforehand and check its placement with respect to the parts that must abut it when the source is fully assembled. Special instructions for aligning the ring gear are provided in section 5.3.

CAUTION

Pay attention to the lengths of the screws you remove at each stage of this disassembly procedure. There are several different screw lengths, and it is critical to replace the correct screws in each location.

- Step 1. Using the Allen tool provided with the unit, remove the 3 socket-head screws that secure the crucible cover to the push rods (see Figure 5-1). Then remove the cover.

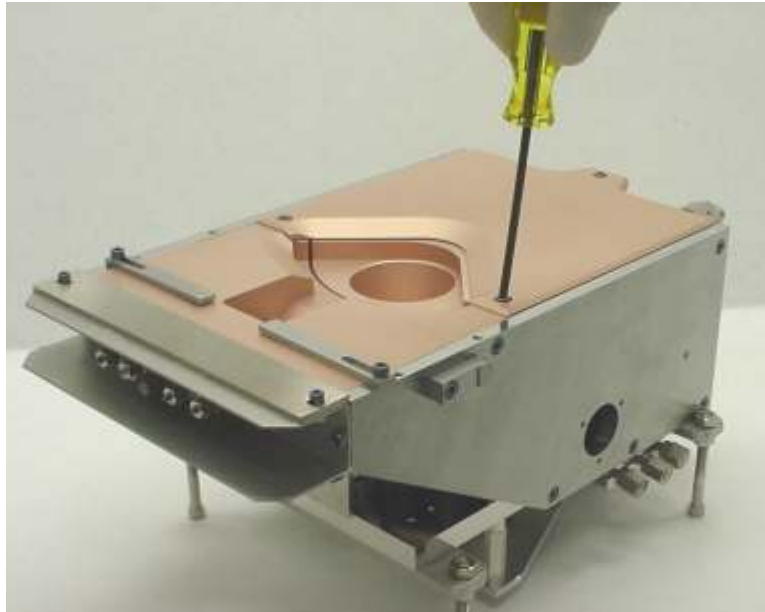

Figure 5-1. Removing the crucible cover

- Step 2. With the source on its side, remove the 10-32 flat-head screw from the center of the spider plate. Note: Use a thin 7/8" open-end wrench applied to the machined hex on the bellows to prevent twisting the bellows.
- Step 3. Pull the spider plate and push rods out through their clearance holes in the coil housing and baseplate. Any push rod, switch, or switch bracket can be changed or replaced by removing their respective screws, fastening them to the base plate.
- Step 4. Remove the eight buttonhead screws, fastening the clamp ring to the top of the pneumatic cylinder and lift off the clamp ring, ensuring that the center hole clears the bellows.
- Step 5. Remove the six socket head screws, fastening the pneumatic cylinder to the base plate to aid cylinder removal from the base plate. Remove the sealing disk. This thin disk is meant to block any gas path through the pivot plate shaft's, mounting screws. Note orientation of sealing disk.
- Step 6. To remove the piston and bellows from the cylinder, use a 7/8" wrench on the machined hex of the bellows and a 5/32" Allen key wrench on the bottom of the piston and loosen.
- Step 7. Inspect and replace any worn o-rings. Note: Inspect the 1/2" o-ring that forms the seal between the piston shaft and pneumatic cylinder.
- Step 8. If this is a bottom-drive source, turn it over and remove the three socket-head screws that secure the drive assembly to the bottom of the source and remove the drive assembly. For instructions on disassembling the drive assembly, see section 5.4.
- Step 9. Now you are ready to remove the screws that secure the crucible to the crucible mounting flange. This procedure involves using the special Allen tool provided with the source, which consists of a standard 7/64" Allen driver with a machined sleeve fitted over the shaft (see Figures 5-2 and 5-3). If you are not experienced with this tool, see the detailed instructions

in steps 3 and 4 under the heading “Removing the Crucible” in section 3.5. If you are proficient in the use of this tool, proceed directly to step 10 of this procedure.

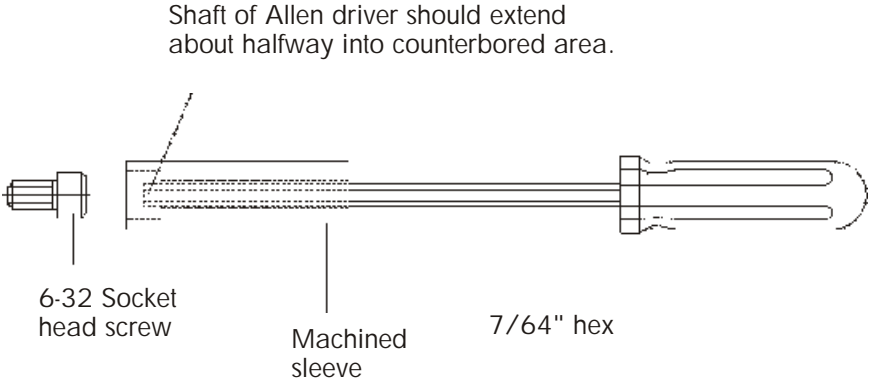

Figure5-2. Detail of the sleeve on the Allen driver



Figure 5-3. Socket-head screw correctly retained by the sleeve on the end of the Allen driver

- Step 10. Remove the screws that secure the crucible to its mounting flange. There are eight of these screws, six of which will be accessible if you turn the crucible to the position shown in Figure 5-4. Perform the following steps in removing these screws:

CAUTION

It is important to follow the procedure described below in removing the crucible mounting screws. The compressed O-ring exerts considerable upward force against the crucible, and the counter-pressure exerted by the mounting screws must be relieved evenly to prevent damage to the screws or the threads in the crucible mounting flange.

- (a) Remove the two screws in the back of the crucible.
- (b) Rotate the crucible 180° and loosen the six remaining screws ½ turn, beginning with the two screws that are now in the rearmost position.
- (c) Remove these six screws, beginning with the two in the rearmost position.

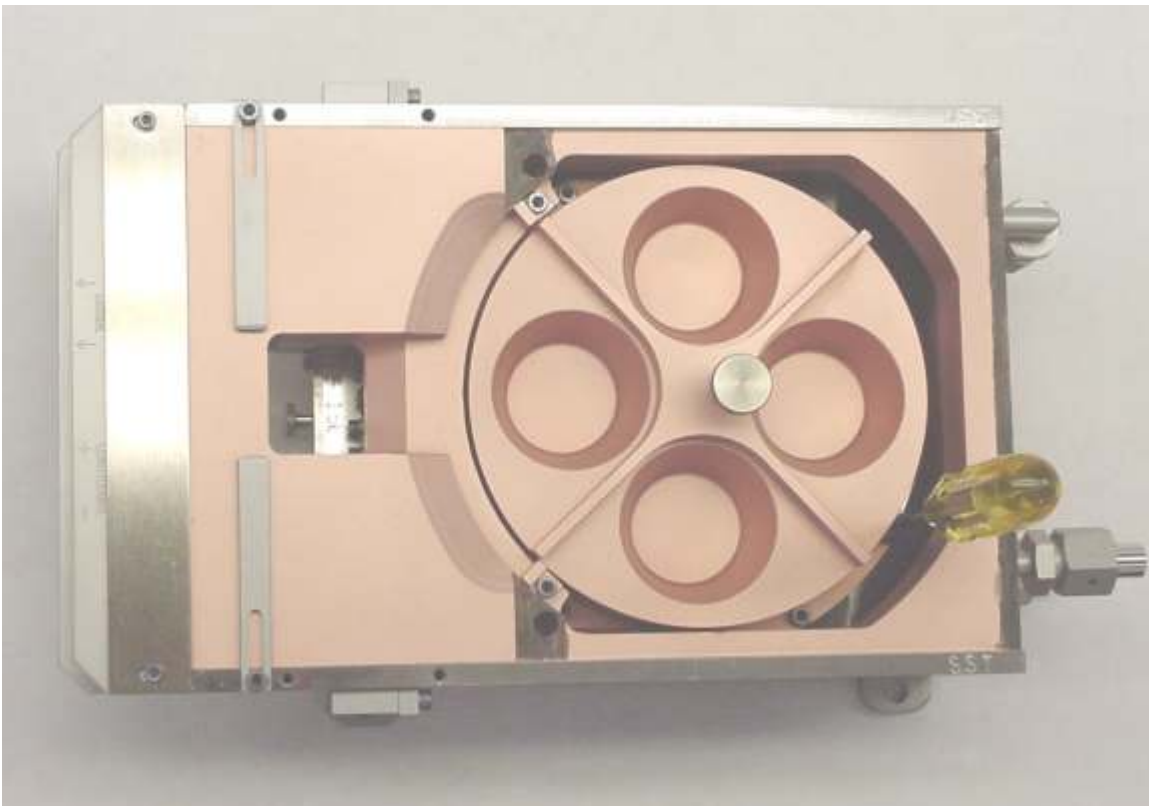

Figure 5-4. Removing the screws that secure the crucible to the crucible mounting flange

- Step 11. Screw the knurled thumbscrew into the tapped hole provided for it in the top of the crucible. Then rotate the crucible so that the off-center thumbscrew is toward the rear of the source.

- Step 12. Remove the crucible from the source, following these steps to avoid damaging the O-ring-sealing surface on the base of the crucible:
- (a) Grasp the knurled thumbscrew and use it to lift the crucible straight up as far as it will go.
 - (b) Raise rear edge of crucible until it just clears the edge of the coil housing to the rear of the crucible.
 - (c) Pull the crucible clear of the coil housing by angling it upward and backward at the same time, as shown in Figure 5-5. At this point, be very careful not to scrape the crucible's O-ring-sealing surface on the water baffle.

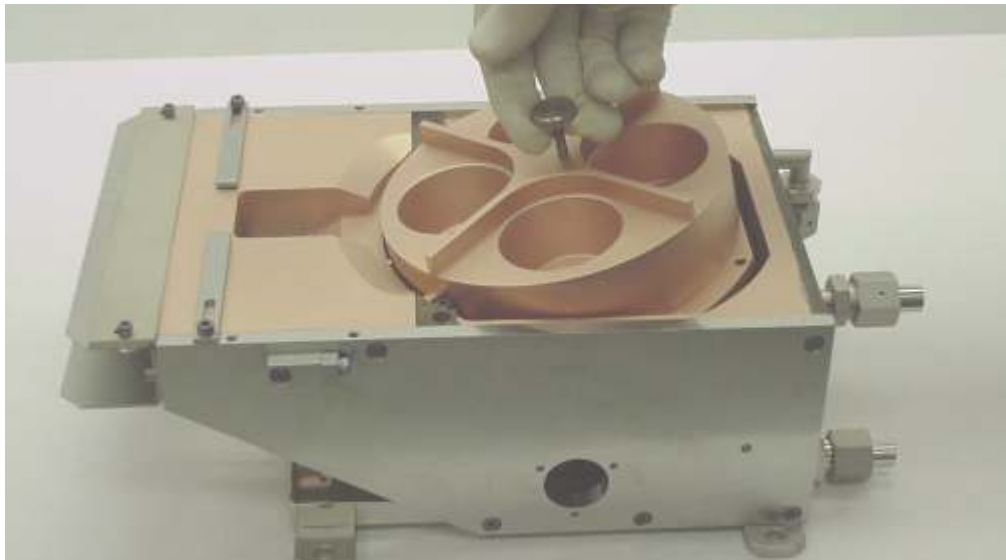

Figure 5-5. Removing the crucible from the source. Note angle of withdrawal

Reassembly Note

It is important to use the special Allen tool correctly when installing the screws that secure the crucible to its mounting flange, so that these screws are not dropped into the recesses of the source. To prevent this from happening, make sure that the tool's sleeve extends as far as possible down over the head of each screw before inserting it into place, as shown in Figure 5-3. Follow these steps when (re-)installing a crucible:

- (a) Position the crucible mounting flange so that you can see six of the eight screw holes.
- (b) Angle the crucible into the position shown in Figure 5-5. Next, lower its rear end so that its bottom surface is horizontal; then lower the crucible straight down onto the O-ring. As you perform this step, take great care to avoid scraping the underside of the crucible's O-ring-sealing surface against the water baffle.
- (c) Rotate the crucible until the six threaded holes in the crucible mounting flange are visible through the holes in the base of the crucible.
- (d) Insert screws into the six accessible holes and screw them down enough to partially compress the O-ring. As you do so, work your way around the periphery of the crucible in a star-shaped pattern, tightening the screws evenly and gradually.

- (e) Rotate the crucible so that the other two screw holes are visible, insert screws into them, and tighten them about the same amount that you have already tightened the other six screws.
 - (f) Work your way around the crucible in a star-shaped pattern, tightening the screws in two more stages, until you can tell that the O-ring is completely compressed.
- Step 13. Remove the emitter assembly, if you have not already done so. First remove the knurled nut that secures the emitter to the source baseplate, as shown in Figure 5-6. Then remove the emitter.



Figure 5-6. Removing the emitter assembly

- Step 14. Remove the two screws that secure the coil shield to the source. Then remove the coil shield and pull the coil assembly straight out of the coil housing.
- Step 15. If this is a side-drive gun, remove the screws that secure the side-drive assembly to the left- or right-hand pole piece, as the case may be.
- Step 16. Remove the screws securing the pole piece extensions to the pole pieces and remove those extensions.
- Step 17. Uncouple the tube connecting the gun's upper and lower water circuits. Using appropriate wrenches, hold the nut soldered onto the fitting connected to the coil housing while turning the coupling on the fitting connected to the base plate (see Figure 5-7).

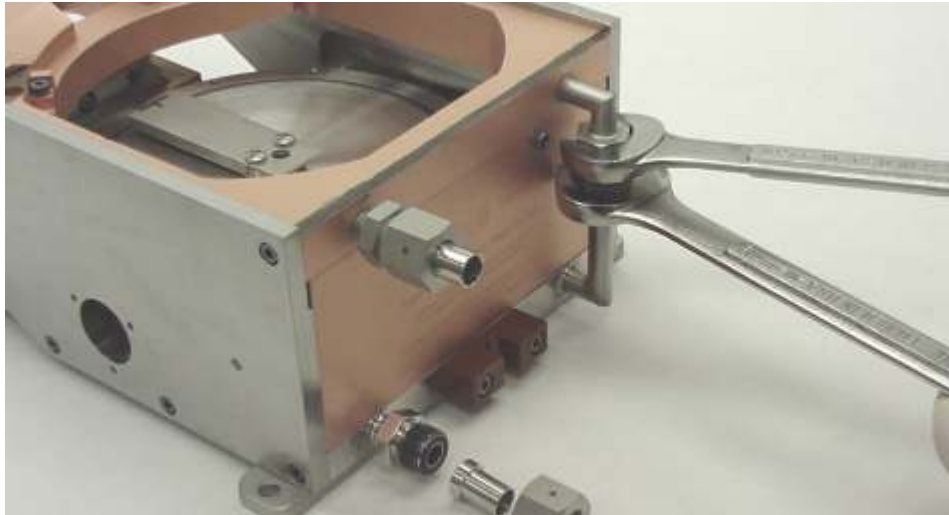

Figure 5-7. Uncoupling the water-crossover tube

- Step 18. Remove the screws that secure the left-hand pole piece to the coil housing and loosen the screws that secure that pole piece to the source base plate (see Figure 5-8).

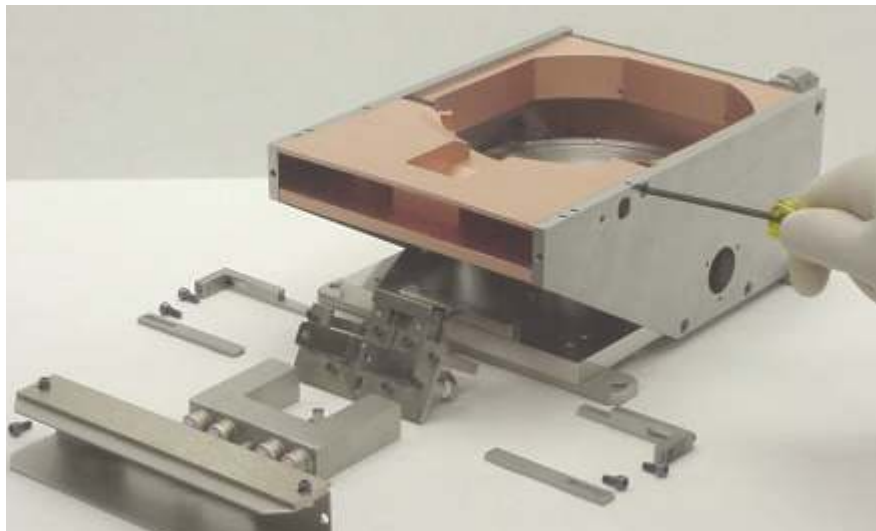

Figure 5-8. Removing the screws that secure the coil housing to the pole pieces

- Step 19. Step : Repeat the same process on the right-hand pole piece.
- Step 20. You should now be able to lift the coil housing free of the pole pieces, as shown in Figure 5-9. If not, further loosen the bottom row of screws that secure one of the pole pieces to the source base plate.

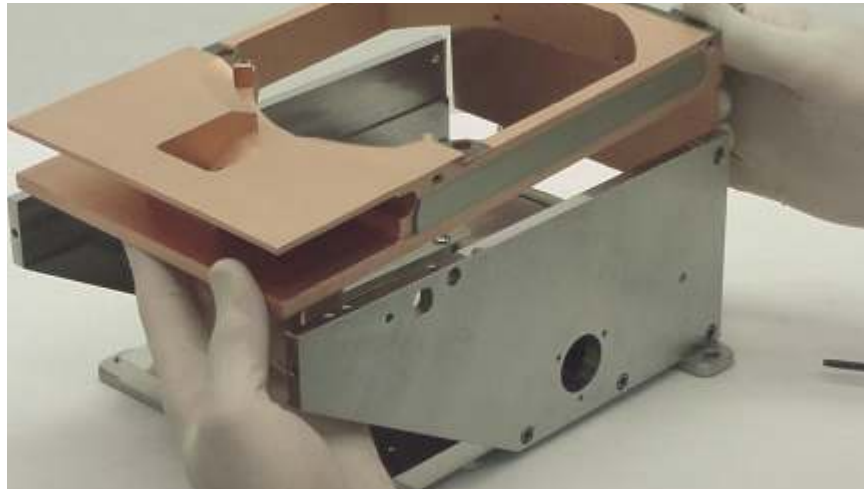

Figure 5-9. Removing the coil housing

Step 21. Remove the screws that secure the pole pieces to the base plate (see Figure 5-10).

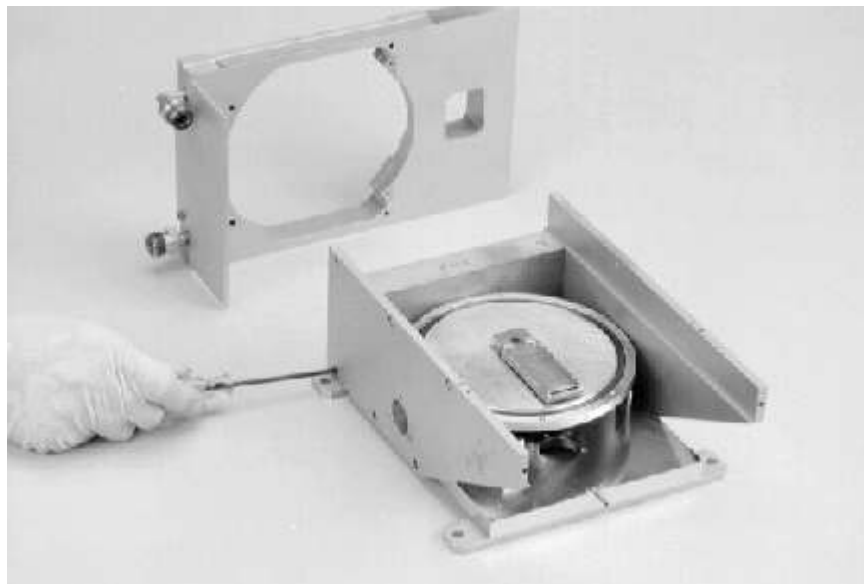

Figure 5-10. Removing the screws that secure the LH pole piece to the base plate

Step 22. Remove the pole pieces from the remainder of the source. To do so, grasp the permanent magnet with one hand and the angled front end of the pole piece with the other, as shown in Figure 5-11. Then swing the front of the pole piece away from the source and carefully separate it from the rear edge of the magnet, rocking it slowly up and down if necessary to break it free from the magnet's very strong field.

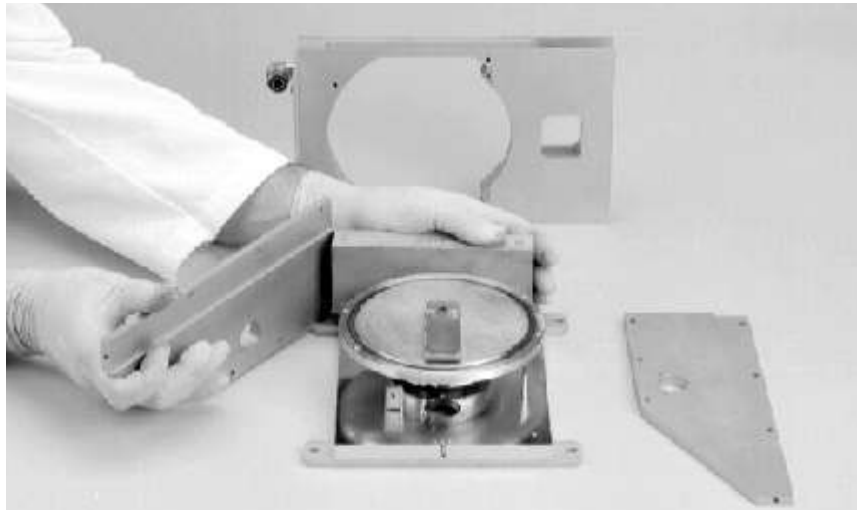

Figure 5-11. Correct technique for detaching pole pieces from magnet and base plate

DANGER

As you perform this step, take care to avoid getting your fingers between the pole piece and any other part of the source. One or more of your fingers could easily be injured if the pole piece should slip from your grasp. In that event, the pole piece could snap back tight against the magnet and base plate with great speed and force, resulting in possible injury to a finger caught between two metallic parts.

- Step 23. Carefully remove the permanent magnet from the base plate. To do so, push it to one side and then swing it up by raising the end that now extends beyond the side of the base plate.

CAUTION

To minimize the risk of degaussing the magnet, always place it on a nonmagnetic surface such as plastic or wood when it is not installed in the source. When handling the magnet, make sure that it does not drop onto or otherwise strike any hard surface.

- Step 24. Remove the two 8-32 \times 1/4-in. screws that secure the water baffle to the pivot shaft and remove the water baffle (see Figure 5-12).

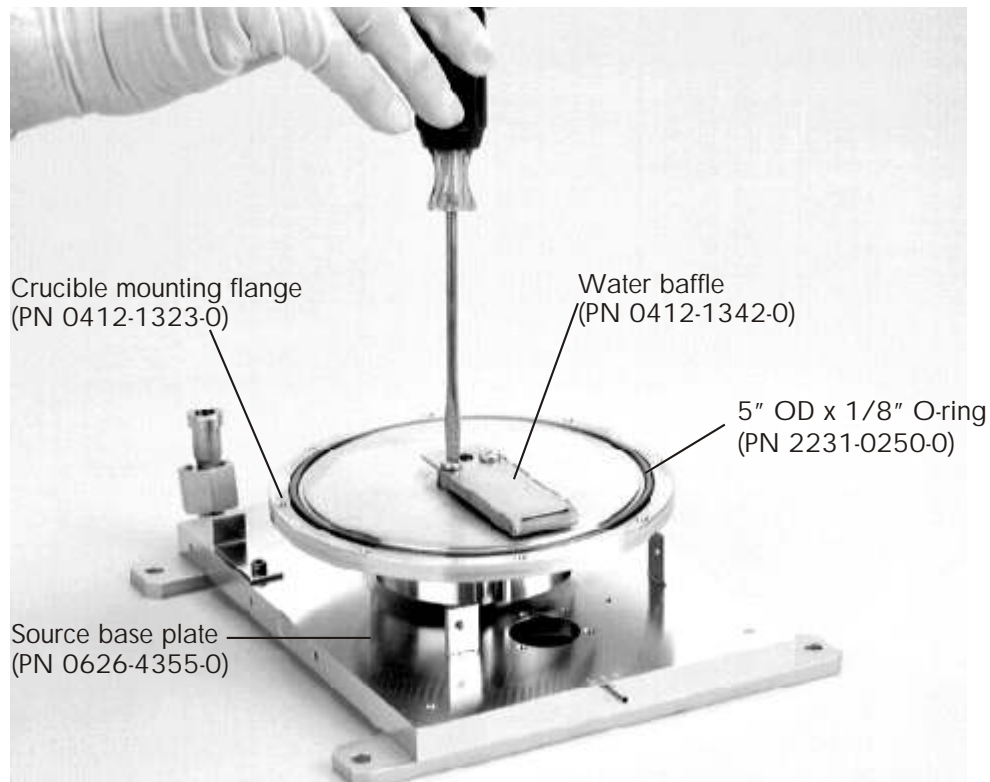

Figure 5-12. Removing the water baffle

- Step 25. Holding the remainder of the source as shown in Figure 5-13, remove the four 6-32 × 3/8-in. screws that secure the pivot shaft to the base plate. Then you can remove the bearing housing assembly (which contains the pivot shaft) from the source.

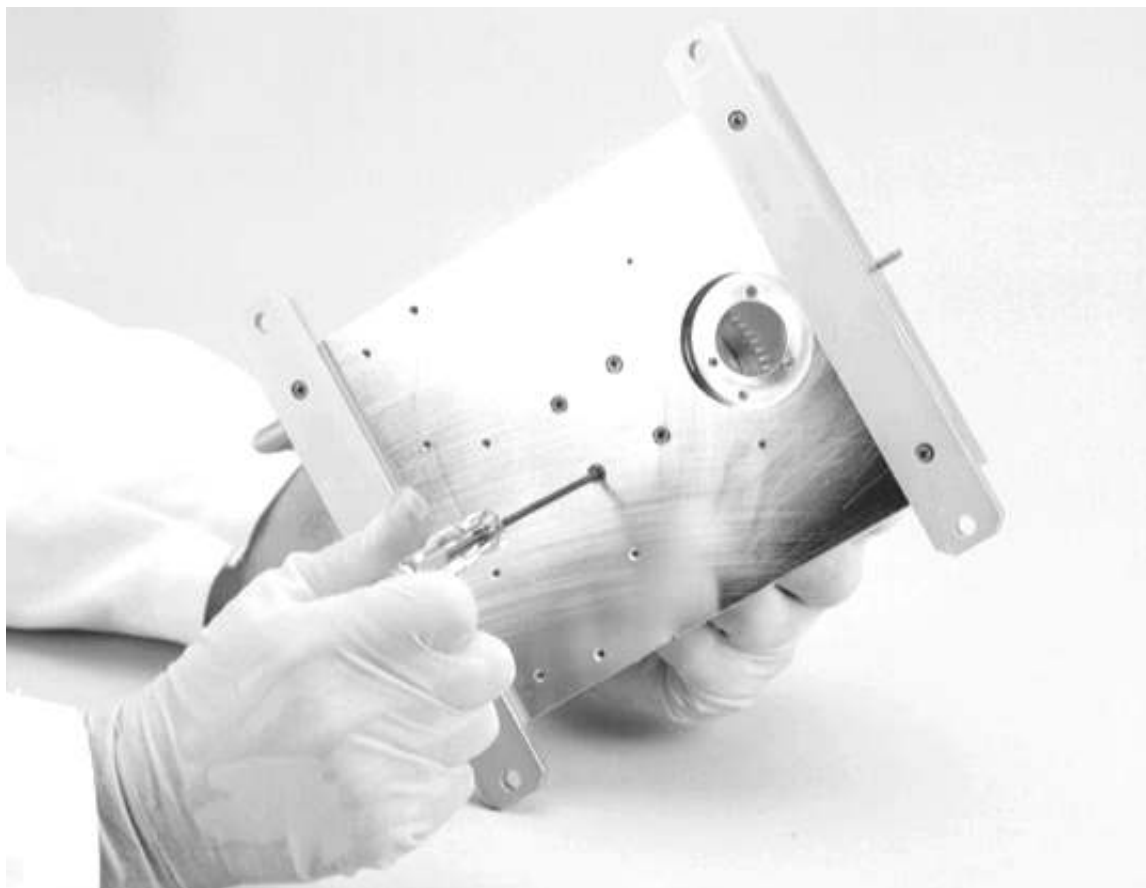

Figure 5-13. Detaching the pivot plate shaft from the base plate

Reassembly Note

The four holes in the base plate for mounting the bearing housing assembly are not arranged in a rectangle but are asymmetrical, with one hole slightly farther off center with respect to the other four. This arrangement ensures that the bearing housing assembly can be mounted in only one orientation, that is, with the water baffle point toward the front of the source. When reassembling, make sure that you can see all four tapped holes in the pivot shaft through the holes in the base plate before you insert and tighten any screws.

- Step 26. Remove the four 6-32 × 5/8-in. screws that secure the bearing housing to the crucible mounting flange. To do so hold the bearing housing-mounting flange assembly in one hand, with the top of the mounting flange facing down. Then insert the Allen driver into the recesses in the bearing housing that hold the four screws and remove them, as shown in Figure 5-14.

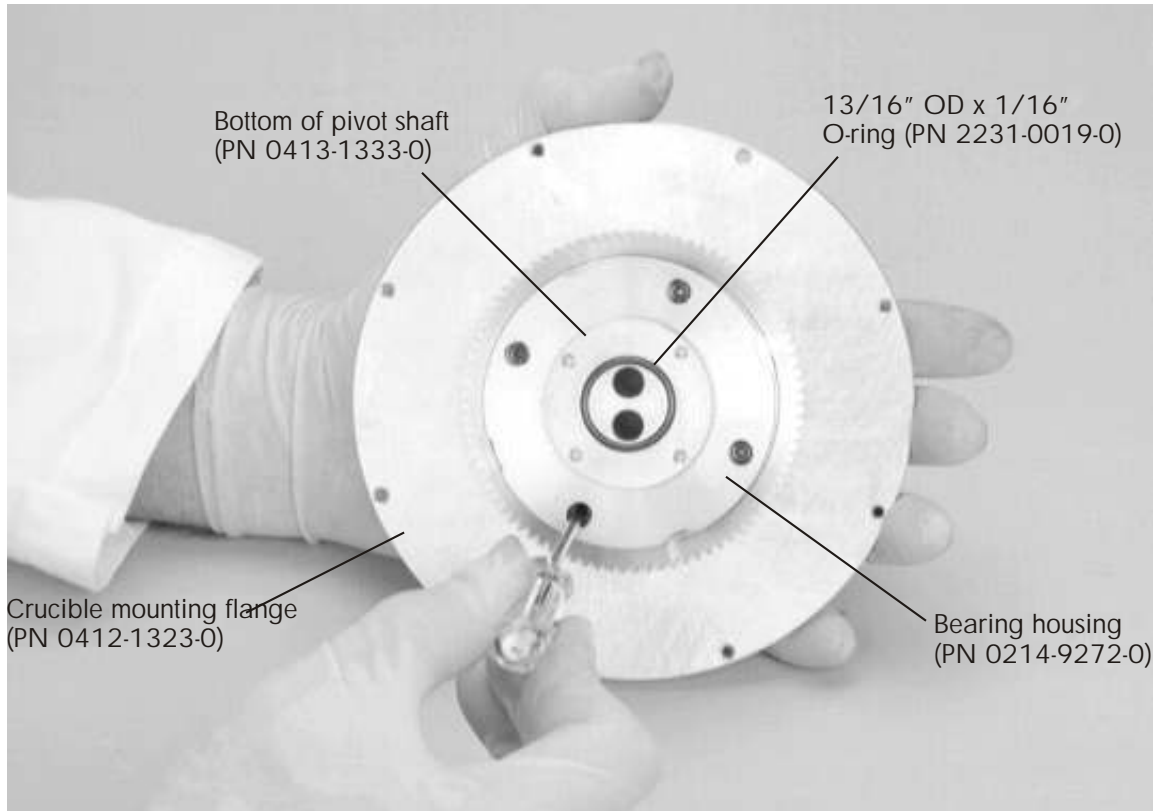

Figure 5-14. Removing the screws that secure the bearing housing assembly to the crucible mounting flange

Figure 5-15 shows the parts disassembled so far, with the following subassemblies still intact:

1. The emitter assembly (see section 4.3 for disassembly instructions and parts illustration)
2. The bearing housing assembly (see section 5.3 for disassembly instructions and parts illustration)
3. The drive assembly (see section 5.4 for disassembly instructions and parts illustration)

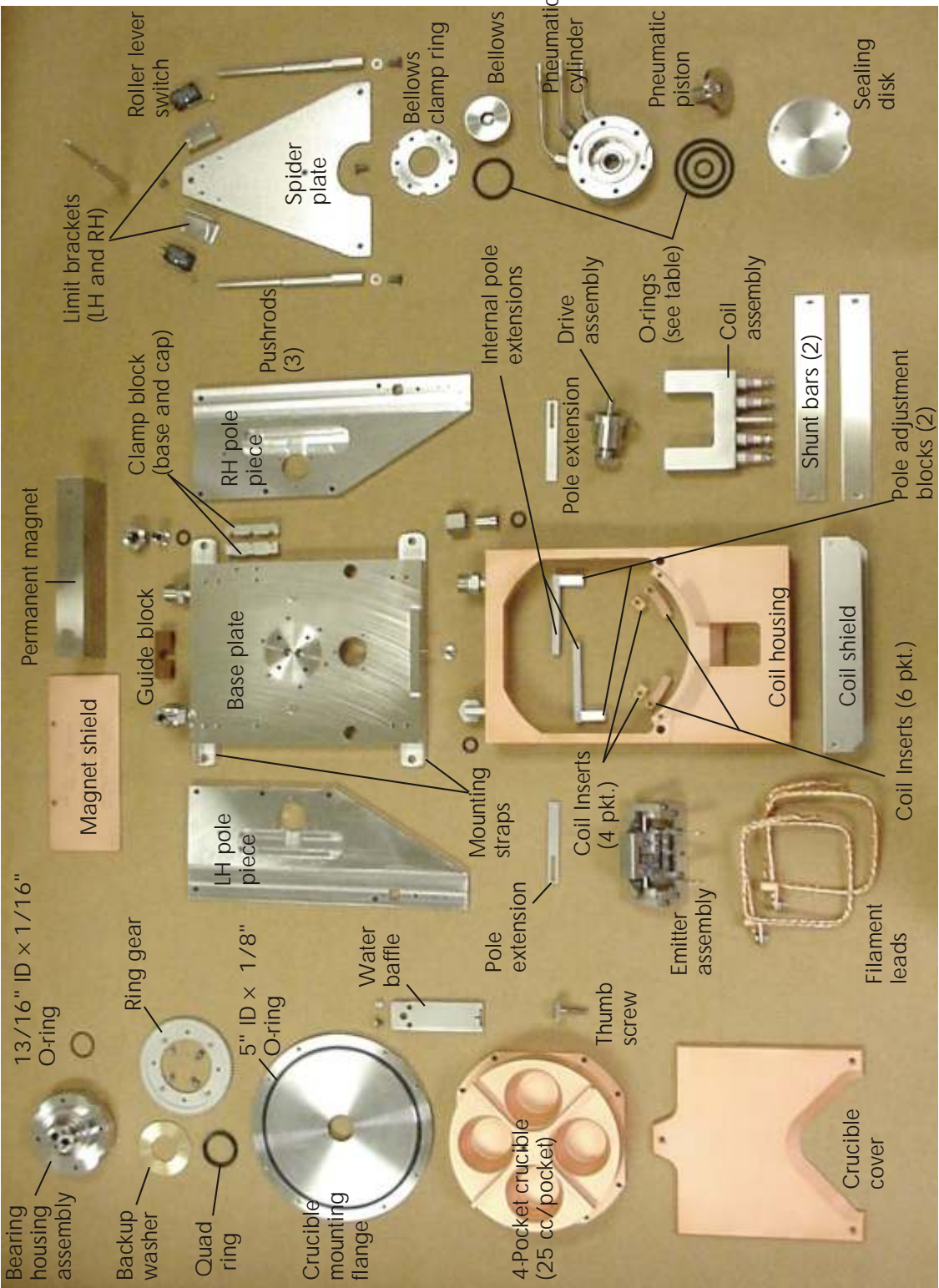

Figure 5-15. Parts layout, STIH-270-2PT source, with emitter, bearing housing assembly, and drive assembly still intact

Part Numbers List for Figure 5-15

Ref#	Item Number	Description
003	2231-0110-1	O-Ring 3/8 ID X 3/32 W VITON
006	0214-9311-0	Shunt Bar STIH-270-2C
008	0626-7434-0	Coil Housing BRZMNT W/VCO PT
010	0303-3292-0	Filament lead
011	0312-6923-0	Coil Assy.
012	0412-1452-0	Coil shield STIH270-2C
013	0626-3784-1	Pole piece LH W/STEP, -2CKE
014	0626-3784-2	Pole pieceRH W/STEP, -2CKE
015	0715-9412-3	Pole ext. .38" X 2.50" X .12" SST
016	0412-1482-1	Magnet Shld STIH 2702 FOR -2 PT
017	0413-3902-0	Magnet STIH 270-2M
019	0626-4355-0	Base Plate for the STIH270-2 PT
020	0412-1542-0	Mounting strap STIH-2
048	1349-4034-0	Thumbscrew
060	0715-8173-1	Insert, Coil HSG, X-Cont 4Pkt -2
061	0715-8173-2	Insert, Coil HSG, X-Cont 6Pkt -2
750	2231-0225-1	O-Ring, 1.859" ID X 1/8" CS
751	2231-0218-1	O-Ring, 1.234" ID X 1/8" CS
752	2231-0112-0	O-Ring, 1/2" (.487") ID X 3/32" CS
799	6156-1210-0	Switch, Simulated roller lever
800	0627-2613-0	Weldment, Bellows, SST, PopTop
801	0627-2663-0	Weldment cylinder, Pneumatic
802	0627-2652-0	Clamp, Ring, Bellows SST

Ref#	Item Number	Description
803	0627-4833-0	Plate, Spider, SST, PopTop
804	0627-4812-0	Pushrod, Solid, -2CK PT SRC
805	0627-2632-0	Disk, Sealing, SST, PopTop
806	0627-2702-0	Block, Guide, Vespel
807	0627-2742-0	Bracket, Limit SW, RH, PopTop
808	0627-2752-0	Bracket, Limit SW, LH, PopTop
809	0627-2722-0	Block, Clamp, VCR Base, PopTop
810	0627-2732-0	Block, Clamp, VCR Cap, PopTop
811	0627-2782-0	Piston, Pneumatic, 1.490" OD
901	0503-2762-0	Ring gear
905	0412-1323-0	Crucible mounting flange
907	0412-1342-0	Water baffle assembly STIH2
909	0414-5712-1	Washer Flt. Bkup. Quad Ring, Bronze
915	2108-0215-0	Ring quad 1-1/16" (1.046") ID X 1/16" CS
916	2231-0019-0	O-Ring, 13/16" (.801") ID X 1/16" CS
917	2231-0250-0	O-Ring 5" ID X 1/8" W VIT

0916-8294-0	High-performance emitter
0627-8144-1	Crucible cover
0715-8454-0	4-pocket crucible

5.3 DISASSEMBLING THE BEARING HOUSING ASSEMBLY

Perform the steps described below and refer to Figures 5-16 and 5-17 when disassembling the bearing housing assembly.

- Step 1. Hold the bearing housing right-side-up and remove the loose spacer from the housing's inner cylindrical surface, if the spacer has not already fallen out of place.
- Step 2. Using a snap ring tool fitted with correct-sized prongs, spread the retaining ring and remove it from around the pivot shaft (see Figure 5-16).

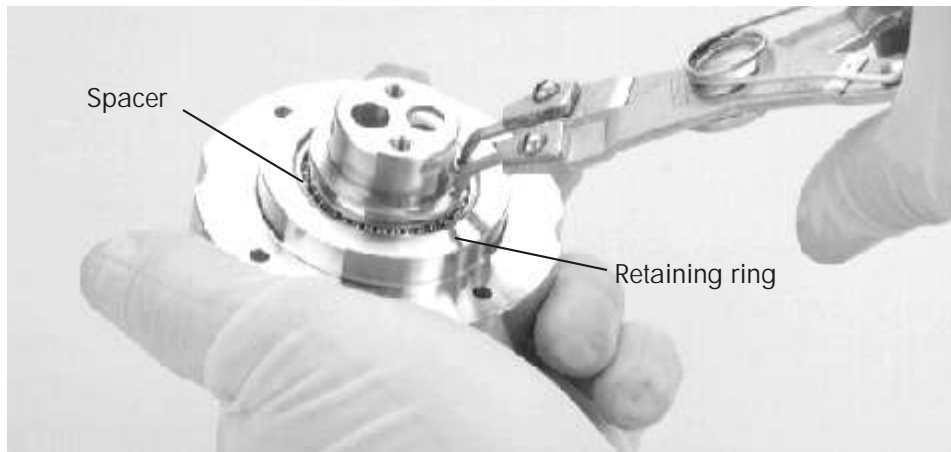

Figure 5-16. Removing the retaining ring

- Step 3. Remove the pivot shaft, upper and lower bearings, and bearing spacer from the bearing housing. Figure 5-17 shows these parts laid out in order of reassembly.

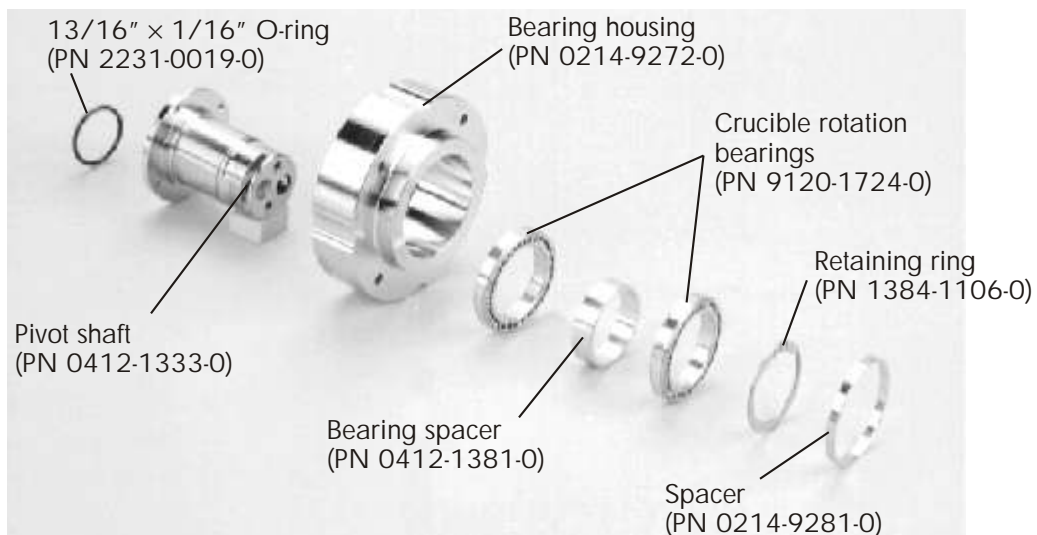

Figure 5-17. Layout of the parts of the bearing housing assembly, in order of reassembly

Reassembling and Installing the Bearing Housing Assembly

Follow the procedures described below when reassembling and installing the bearing housing assembly. Perform these procedures in the order in which they appear.

Procedure 1: Parts Inspection

Carefully inspect the pivot shaft before reassembling the bearing housing assembly, paying close attention to the top of the pivot shaft and its quad ring sealing surface. The top of the pivot shaft must be free of burrs to prevent the quad ring from being damaged during assembly. Use Scotchbrite or similar products to polish small marks out of the quad-ring-sealing surface. If deep scratches remain, replace the pivot shaft.

Procedure 2: Drive gear installation

Perform this procedure only if you have removed the drive gear from the crucible mounting flange.

- Step 1. Using the correct mounting screws, loosely secure the drive gear to the crucible mounting flange, so that the gear can still be moved about slightly.
- Step 2. Insert the bearing housing assembly into the hole in the crucible mounting flange and use the outer surface of the bearing housing to center the ring gear.

CAUTION

Take care to avoid jamming or scratching these parts during this step, as the fit between the bearing housing and the crucible mounting flange is very close.

- Step 3. Rotate the bearing housing until its through-holes line up with the screws that secure the drive gear to the crucible mounting flange.
- Step 4. Insert the Allen driver through these holes and tighten these screws, as shown in Figure 5-18.

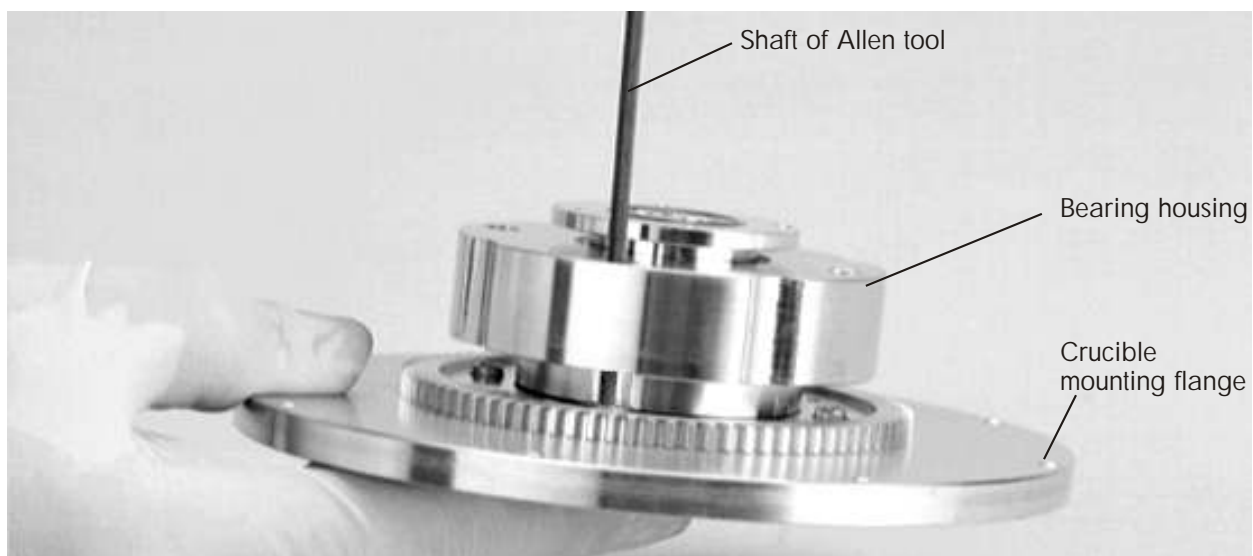

Figure 5-18. Allen driver inserted through hole in the bearing housing

Step 5. Remove the bearing housing from the crucible mounting flange.

Procedure 3: Reassembly of Bearing Housing Assembly

Step 1. Put the pivot shaft in place inside the bearing housing, making sure that both parts face the correct direction. Figures 5-16 and 5-17 show these parts correctly assembled.

Step 2. Carefully slide the two bearings and the thicker bearing spacer into the space between the pivot shaft and the bearing housing. Be very careful to avoid jamming any parts or scratching the pivot shaft as you do so.

CAUTION

The bearings in this assembly are precision bearings and must be handled carefully.

Step 3. Put the retaining ring in place, using the same snap-ring tool you used during disassembly.

NOTE

There will be approximately 1/8" of vertical play between the part of this assembly until it is secured to the crucible mounting flange.

Procedure 4: Quad Ring Installation

Step 1. Check to make sure that the bronze backup washer and the crucible mounting flange will slide over the pivot shaft without binding.

Step 2. Place the crucible mounting flange upside down on a clean work surface (i.e., with the counterbored seat for the quad ring facing upward).

Step 3. Liberally lubricate the quad ring with a low vapor pressure (Apiezon L or equivalent). When the ring is correctly lubricated, all four of its grooves should be at least partially full of grease.

Step 4. Carefully work the quad ring into the counterbore in the crucible mounting flange.

Procedure 5: Attaching the Bearing Housing Assembly to the Crucible Mounting Flange

Step 1. With the crucible mounting flange in the same position, put the bronze backup washer in place in its counterbore, directly on top of the quad ring.

Step 2. Place the bearing housing assembly right-side-up on the work surface (i.e., with the assembly resting on the pivot shaft's lower end, which has the O-ring groove).

Step 3. Set the thinner bearing spacer in place in the top bore of the bearing housing.

Step 4. Pick up the crucible mounting flange and turn it over, holding the bronze backup washer against the quad ring to keep it from moving.

Step 5. Holding the backup washer this way, carefully work the mounting flange onto the pivot shaft, twisting or rocking the flange slightly to allow the quad ring to slide over the top lip of

the pivot shaft. If your technique is correct, stretching the quad ring over the pivot shaft should require only a light downward pressure.

CAUTION

Do NOT force the quad ring onto the pivot shaft. Doing so may damage the quad ring, rendering it incapable of providing a water-tight seal.

- Step 6. When you have pushed the leading edge of the quad ring past the water outlet slot, let go of the backup washer and withdraw your fingers. Then push the mounting flange all the way down onto the pivot shaft.
- Step 7. Once the mounting flange is all the way down on the pivot shaft, hold these two parts together and rotate the mounting flange until the holes in the bearing housing are lined up with the threaded holes in the mounting flange.
- Step 8. Install the four 6-32 × 5/8-in. mounting screws, snugging them down gradually in a cross-wise patten to prevent the bearing housing from becoming cocked in the mounting flange's bore. Torque the mounting screws to 8 in.-lbs.
- Step 9. Rotate the pivot shaft by hand to make sure there is no binding as it turns.
- Step 10. Secure the water baffle to the top of the pivot shaft, using the pan-head screws provided (see Figure 6-12).
- Step 11. Check again for any trace of binding during pivot shaft rotation. This time, hold the mounting flange in one hand and push the water baffle with one finger of the other hand to rotate the pivot shaft. The quad ring should produce a light, even resistance as the pivot shaft rotates. If the resistance is heavy or uneven, remove the mounting flange from the bearing housing assembly and check to see that the quad ring has not become cut or twisted. Check also for parts that seem improperly installed or are out of tolerance.

Before reinstalling this assembly on the source baseplate, apply low vapor pressure (Apiezon L or equivalent) to the O-ring that fits between the baseplate and the pivot shaft and place this O-ring in the groove in the bottom of the pivot shaft.

Procedure 6: Vacuum Leak Check of Assembly

Perform this check after the gun is fully reassembled, except for the crucible cover.

- Step 1. Connect the gun to a leak detector with a sensitivity of 1×10^{-9} std. Atm cc/sec or better.
- Step 2. Initiate the instrument's test mode and note its base leak rate (i.e., its leak rate before helium is applied to the gun). This reading indicates whether there is any residual helium in the detector that should be removed before you test the gun. Alternatively, the base rate can be subtracted from the test reading.
- Step 3. Apply helium to all the external surfaces of the gun while observing the leak rate, which should not exceed 3×10^{-9} std. Atm cc/sec at any point.

- Step 4. Rotate the crucible while directing the helium flow toward the area where the quad ring resides (i.e., the area where the crucible mounting flange fits around the pivot shaft). The leak rate there should not exceed 5×10^{-9} std. Atm cc/sec.
- Step 5. If the leak rate indicated following either step 3 or step 4 is higher than the value specified for that step, remove the helium from the gun and give the detector time to stabilize at its base leak rate. Then repeat steps 2-4. If the base leak rate is still high when you repeat step 2, then you can conclude that residual helium is building up within the detector during the testing procedure, so there is probably not a significant leak in the gun. However, if repeating step 2 yields a base leak rate close to the value you obtained when you first performed step 2, *and* if you obtain a high reading upon repeating either step 3 or step 4, then you can conclude that there is a leak in the gun. In that event, locate the source of the leak and correct it. Then repeat the test.

5.4 DISASSEMBLING THE DRIVE SHAFT ASSEMBLY

Follow the steps described below in disassembling the drive shaft assembly.

- Step 1. Hold the drive shaft assembly in one hand, with the shaft extending toward you, as shown in Figure 5-19. Using a snap-ring tool with the correct-sized prongs, remove the retaining ring that holds the outer drive bearing in place in the bearing housing.



Figure 5-19. Removing the retaining ring that secures the outer crucible drive bearing in the bearing housing

- Step 2. Using a small flat-bladed screwdriver, pry up and outward on one point of the retaining ring that fits around the drive shaft (see Figure 20).



Figure 5-20. Removing the retaining ring that retains the drive shaft

- Step 3. Holding the bearing housing in the same position, withdraw the drive shaft from the assembly.
- Step 4. Turn the bearing housing over and drop the bearings and the spacer into your other hand. Do NOT let the bearings fall onto the floor or a work surface, as they are easily damaged.

In most cases, it will not be necessary to remove the drive gear from the drive shaft. However, doing so is simply a matter of loosening the two set screws that secure the gear to the shaft and then working the gear off of the shaft. If yours is a bottom-drive source, there will be no Woodruff key. Instead, the gear will be secured to the shaft with a roll pin. In the case of side-drive unit, the gear is held in place on the shaft by a woodruff key. Supporting the bottom of the gear hub, drive out the shaft using a hammer and a small diameter drift. When hammering the drift ensure that the woodruff key does not rotate in its seat and jam in the keyway.

REASSEMBLY NOTE

Follow the steps described below and refer to Figure 5-21 when reassembling the drive shaft assembly.

- (a) Reattach the drive gear to the drive shaft, if you have disassembled these parts.
- (b) Put the two bearings and the spacer in place inside the drive-bearing housing.
- (c) Insert the drive shaft into the assembly.
- (d) Replace the retaining ring that secures the drive shaft. To do so, place the points of the retaining ring against the groove in the drive shaft. Then squeeze the ring against the shaft with a pair of needle-nosed pliers until the ring snaps into place around the shaft. Make sure the retaining ring is properly seated in its groove in the drive shaft.

The following applies to Bottom-drive source:

- (e) Insert the drive shaft assembly through the hole of the base plate so that the pinion gear meshes with the ring gear.
- (f) Loosely tighten the three mounting screws.
- (g) Gently rotate the crucible mounting flange and check for proper meshing of the pinion gear.
- (h) Firmly tighten the three mounting screws of the drive shaft assembly.

The following applies to side-drive source:

- (e) Slightly loosen the two set-screws that are holding the gear onto the drive shaft.
- (f) Insert the drive shaft assembly through the side hole of the source assembly so that the bevel pinion meshes with the ring gear.
- (g) Tighten the three mounting screws
- (h) Adjust the position of the bevel pinion the drive shaft so that the pinion meshes with the ring gear properly. Check the assembly by rotating the crucible mounting flange.
- (i) Tighten the two set screws on the bevel pinion.

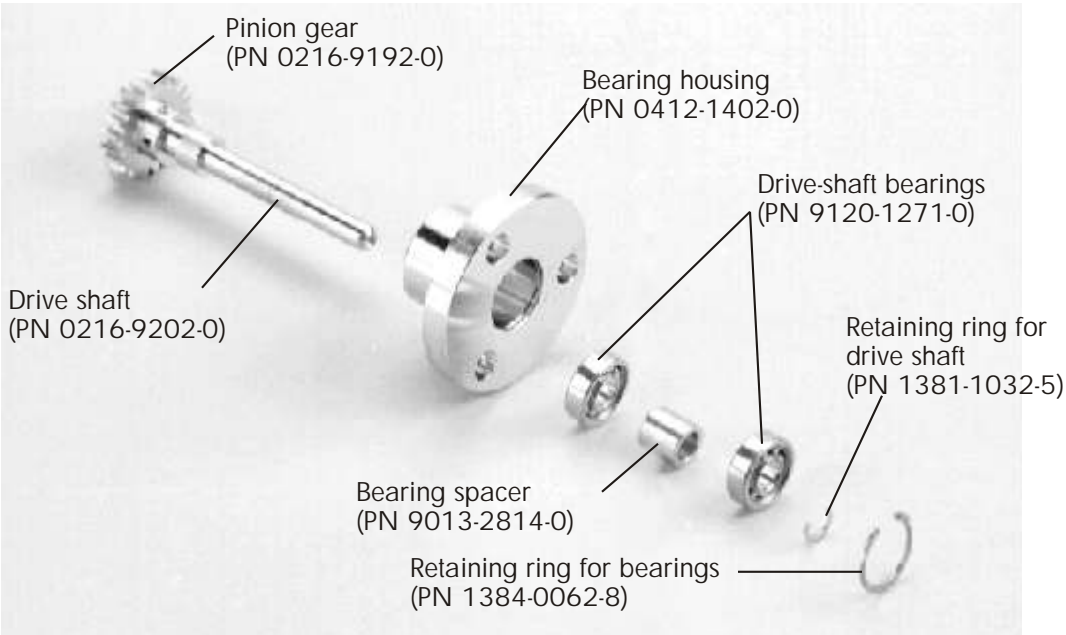

Figure 5-21. The parts of the drive shaft assembly laid out in order of reassembly

SECTION 6

TROUBLESHOOTING

6.1 SECTION OVERVIEW

This section provides a troubleshooting guide that correlates specific symptoms to probable causes and suggested corrective actions. To facilitate your troubleshooting efforts, these symptoms are classified according to type of malfunction and organized in the following subsections:

- 7.2 Difficulties in generating or maintaining a beam
- 7.3 Unsatisfactory performance during deposition
- 7.4 Beam-position problems
- 7.5 Other Malfunctions

6.2 DIFFICULTIES IN GENERATING OR MAINTAINING A BEAM

NO.	SYMPTOM	PROBABLE CAUSE	CORRECTION
1	High voltage is nominal, but there is no emission current and no filament current. (See power supply instruction manual for nominal operating values.)	(a) Filament is broken or loose. (b) Resistance between bus bars is high because of oxide buildup on filament clamps. (c) Fault in circuit supplying filament current.	(a) Using ohmmeter, check continuity between filament bus bars. Make sure that filament legs are properly seated in V-grooves and that the filament clamp screw is tight. (b) Use ohmmeter to test resistance between bus bars. Reading should be no more than 0.3 ohms. If greater, replace filament after cleaning oxides from contact surfaces (see section 4.2 for instructions). (c) Check the e-beam power supply's gun control circuit and the connections between that circuit and the gun.
2	Emission current is at maximum value, and filament current is nominal, but there is no high voltage.	(a) High voltage is shorted to ground.	(a) Check for broken insulators or shorted emitter, filament leads, or HV feedthroughs. Replace parts found to be defective.
3	No filament current.	(a) Filament is broken. (b) Heavy oxide buildup on contact surfaces to which filament mounts. (c) Fuse F1 on Simba gun control board is blown.	(a) Check continuity between filament clamps. If infinite resistance is indicated, filament is broken; replace it. (b) Use ohmmeter to check resistance between filament bus bars. If greater than 0.3 ohms, replace filament after cleaning oxides from contact surfaces (see section 4.2 for instructions). (c) Check F1, which is near the board's edge connector, and replace as necessary.
4	Filament burns out when energized.	(a) Too much filament current is being applied to the filament.	(a) Fault in gun control circuit. Either an output transistor or the triac is shorted out. Check these components and replace them as necessary.

6.3 UNSATISFACTORY PERFORMANCE DURING DEPOSITION

NO.	SYMPTOM	PROBABLE CAUSE	CORRECTION
1	High voltage and emission current values go up and down independently of controls, and there is visible arcing or heating at the high-voltage insulators.	(a) Insulating capability of one or both HV feedthroughs is breaking down because they are fractured or coated, but they are not yet shorted to ground. (b) In-vacuum HV lead(s) dirty and making contact only intermittently.	(a) Examine the HV insulators. If they are coated, clean them by glass-bead honing. If damaged, replace them. (b) Clean leads by glass-bead honing and reconnect securely.
2	High voltage and emission current are nominal, but filament current is high. (See power supply instruction manual for nominal operating values.)	(a) Two or more loops of the filament's coils are shorted together.	(a) Examine filament carefully; replace it if the coil's loops are touching each other.
3	High voltage, emission current, and filament current are all nominal, but the melted material is either alloying with or eroding the crucible. Cooling water may also be boiling. <i>NOTE: Alloying creates a direct thermal short, which will destroy crucible in time. If wetting has occurred, the material MUST be decoupled from the copper before operation is resumed. This can only be accomplished by glass-bead honing the crucible.</i>	(a) Stationary beam spot is too close to the edge of the pocket. (b) Inadequate cooling of exposed pocket.	(a) Apply beam sweep, if possible, or adjust deflection current(s) so that the beam is centered in the pocket. (b) Check to see that the gun's cooling water is chilled to max. 20° C and that its flow rate is at or above the minimum value specified in section 1.4.
4	Emission current is limited at some value below its 1.5-A maximum.	(a) Beam former is shorted to gether. (b) Emission current is limited because: (1) Filament is installed backwards; (2) not enough filament is exposed; (3) there are shorted loops on the filament's coil; (4) the filament is badly warped; or (5) anode is too far from filament. (c) One of the flanged insulators in the emitter assembly is badly coated.	(a) Realign beam formers to correct gap so they are no longer shorting (see section 4.4). (b) Check condition of filament. If it is installed incorrectly, has shorted turns, or is warped, replace it. If no filament problems are detected, check position of anode relative to filament. (See section 4.2 when checking the positions of these parts.) (c) Disassemble emitter far enough to check condition of flanged insulators. If coated, replace them.*

* Generally, it is possible to clean the insulators on HV feedthroughs by glass bead honing without damaging them. However, it is best to replace the ceramic insulators in the emitter when they become coated, as they can only be cleaned abrasively, which usually results in serious damage. If you wish to try to clean these insulators as a stopgap measure, handle them very carefully and apply the abrasive using as little force as possible.

Troubleshooting

NO.	SYMPTOM	PROBABLE CAUSE	CORRECTION
4 cont.		(d) Bad connections to HV leads, which may involve the connections to the filament bus bars, the connections to both sides of the HV feedthroughs, or the connections to the filament transformer. (e) Voltage of filament current is low. (This voltage should be 12 V ac.)	(d) Check for loose connections or oxidized surfaces at all HV terminals. If surfaces appear oxidized, sand or file them until bright. Clean in-vacuum filament leads by glass-bead honing and reattach them, being sure to make tight, secure connections. (e) Check the connections at the filament transformer and the output of the e-beam power supply's gun control circuit.
5	Short filament life.	(a) Vacuum chamber does not evacuate properly below 5×10^{-4} torr.	(a) Leak-check the vacuum chamber. Clean system. If hivic pump is a diffusion pump, change its oil. If it is a cryopump, change its trap.
6	Pronounced drop in deposition rate.	(a) Beam density may be too high, causing cavitation of molten pool. (b) The permanent magnet is so weak that the beam cannot be centered longitudinally. (c) Magnetic interference from another e-beam source mounted in the same chamber. (d) Other magnetic fields are affecting beam position. (e) Inadequate cooling.	(a) Reduce beam density by exposing more of the filament or by changing the position of the pole piece extensions. (b) With gun operating at low power, check beam-spot position with zero longitudinal coil current applied. If spot is too far toward rear of source (see Figure 6-1), replace permanent magnet or have it regaussed. (c) Make sure that magnetic shielding is correctly installed between the sources (see section 2.4 for instructions). (d) Make sure gun is isolated as completely as possible from any other possible source of magnetic interference. (e) Check to see that the gun's cooling water is chilled to max. 20° C and that its flow rate is at or above the minimum value specified in section 1.4.
7	Beam power will not go above 5 kW.	(a) Filament is installed backward.	(a) Install new filament, making sure that it is installed the right way around. (See section 4.2 for instructions on replacing filaments.)
8	Emission current drifts after a long period of operation.	(a) One or more of the emitter's flanged insulators is cracked.	(a) Disassemble emitter far enough to check condition of the flanged insulators. Replace any cracked insulators found.
9	Evaporation rate drops and, concurrently there is a significant broadening of the beam spot. In addition, the cooling water may boil if the lateral 'tails' of the beam spot touch the edges of the pocket.	(a) Filament has become warped.	(a) Replace the filament, making sure that 1/4 to 1/3 of the filament's coil is visible below the beam former.

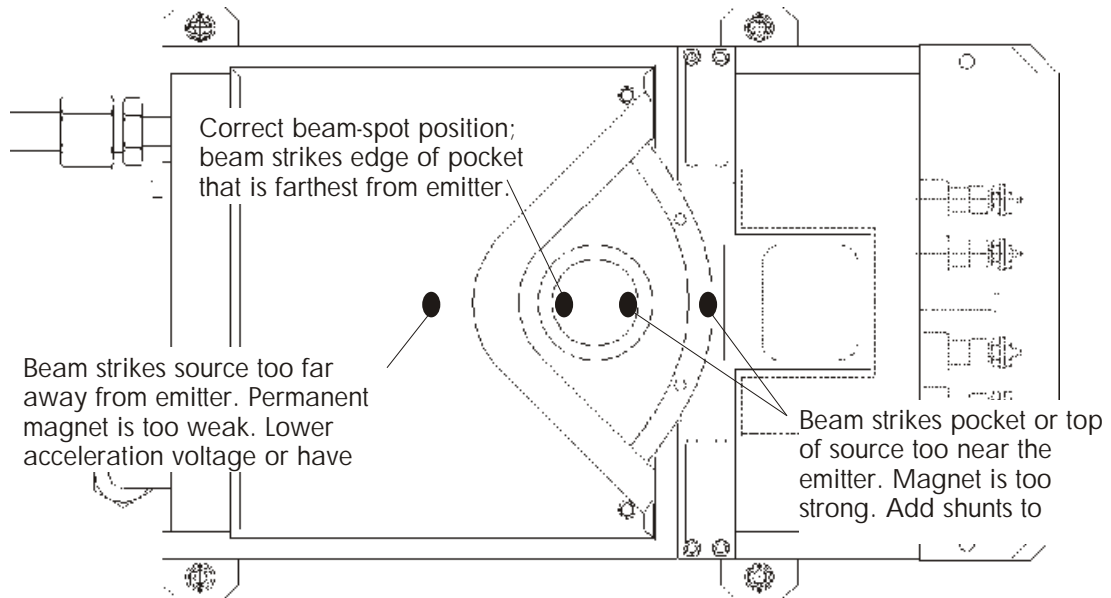

Figure 6-1a. Correct and incorrect beam-spot positions on sources designed for use with non-bipolar sweepers and e-beam power supplies with longitudinal beam position control. Diagram assumes acceleration voltage is 10 kV.

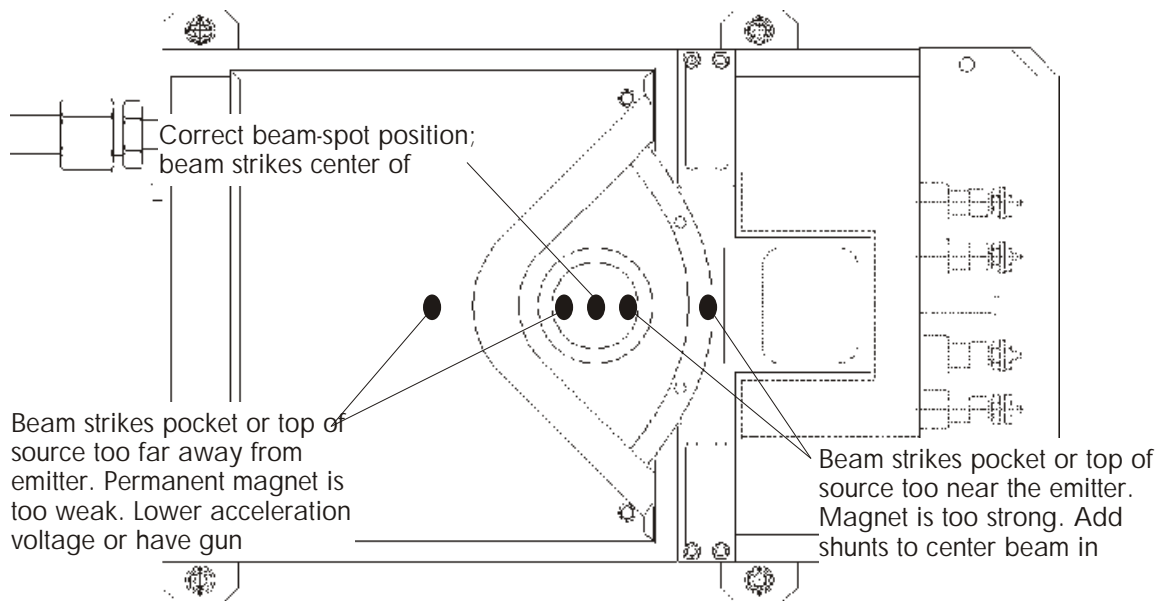

Figure 6-1b. Correct and incorrect beam-spot positions on sources designed for use with bipolar beam sweep controllers

Figure 6-1. Correct and incorrect beam-spot positions with 0 A longitudinal deflection current applied

6.4 BEAM-POSITION PROBLEMS

NO.	SYMPTOM	PROBABLE CAUSE	CORRECTION
1	High voltage, emission current, and filament current are all nominal, but excessive longitudinal current is required to center beam in pocket. (See power supply manual for nominal operating values.)	<p>(a) Weak permanent magnet.</p> <p>(b) Longitudinal deflection coil is partially shorted internally.</p>	<p>(a) Check beam-spot position with 0 A longitudinal deflection current applied. If spot is too far toward rear of source (see Figure 6-1), replace permanent magnet or have it regaussed.</p> <p>(b) Test internal resistance of longitudinal coil. Replace coil assembly if measured resistance is not between 2.2 and 2.4 ohms.</p>
2	High voltage, emission current, and filament current are all nominal, but the beam is not centered longitudinally.	<p>(a) Longitudinal deflection current is set to incorrect value.</p> <p>(b) The permanent magnet is weak.</p>	<p>(a) Adjust longitudinal deflection current.</p> <p>(b) Check beam-spot position with 0 A longitudinal deflection current applied. If spot is too far toward rear of source (see Figure 6-1), replace permanent magnet or have it regaussed.</p>
3	High voltage, emission current, and filament current are all nominal, but beam spot is either off center or asymmetrical in the lateral axis.	<p>(a) Lateral deflection coil is energized.</p> <p>(b) The midpoint of the filament is not aligned exactly between the pole pieces.</p> <p>(c) Pole pieces or pole piece extensions are damaged.</p> <p>(d) Pole pieces are not mounted tight against permanent magnet.</p> <p>(e) Pole piece extensions are not adjusted symmetrically.</p> <p>(f) Interference from another source mounted in same chamber.</p> <p>(g) Either the two lateral deflection coils are shorted together, or one of them is shorted internally or to ground.</p>	<p>(a) Check to see whether any lateral deflection current is being applied. If so, adjust it to 0 A.</p> <p>(b) Make sure that the filament is positioned correctly and that it is not warped or sagging.</p> <p>(c) Examine these parts for signs of damage; replace parts as necessary.</p> <p>(d) Loosen screws securing pole pieces to coil housing and source baseplate. Readjust position of pole pieces as needed to ensure that both are touching the magnet, then retighten screws to 8 ft.-lbs.</p> <p>(e) Check positions of extensions and adjust them as necessary (see section 3.2 for instructions).</p> <p>(f) Make sure that magnetic shielding is correctly installed between the sources (see section 2.4 for instructions).</p> <p>(g) Using ohmmeter, test resistance between the two lateral terminals of the coil assembly and between each of these terminals and ground. There should be infinite resistance between either terminal and ground. Resistance between the two terminals should measure between 3.0 and 3.2 ohms. Replace coil assembly if lateral coil fails either test.</p>
4	Adjusting beam-position controls has no effect on beam position in either axis.	<p>(a) No deflection current is being applied to coils.</p>	<p>(a) Coil leads are disconnected or shorted internally. Make sure they are properly connected. Then check them for shorts.</p>

6.5 OTHER MALFUNCTIONS

NO.	SYMPTOM	PROBABLE CAUSE	CORRECTION
1	Cooling water is boiling, as indicated by a medium-frequency whine coming from the chamber.	(a) Alloying of melted material is causing a thermal short because stationary beam is at edge of pocket. (b) Inadequate cooling of exposed pocket. (c) Weak permanent magnet.	(a) Apply beam sweep, if possible, or adjust deflection current(s) so that the beam is centered in the pocket. (b) Make sure that cooling water is chilled to max. 20 C and that its flow rate is at or above the minimum value specified in section 1.4. (c) Check beam-spot position with 0 A longitudinal deflection current applied. If spot is too far toward rear of source (see Figure 6-1), have the permanent magnet regaussed or replace it.
2	Rapid loss in field strength of permanent magnet.	(a) Gun is being affected by fields from leads connected to some other ac device inside the chamber. (b) Magnet has been dropped or struck against a hard surface. (c) Gun has been heated above its maximum bakeout temperature of 150° C.	(a) Reroute the leads of the other ac device as far away from the gun's permanent magnet as possible. Then check beam-spot position with 0 A longitudinal deflection current applied. If spot is too far toward rear of pocket (see Figure 6-1), replace permanent magnet or have it regaussed. (b) Check beam-spot position with 0 A longitudinal deflection current applied. If spot is too far toward rear of source (see Figure 6-1), replace permanent magnet or have it regaussed. (c) Same as (b).
3	Anode is burned through.	(a) Anode has become directly exposed to the electron beam.	(a) Install new anode, making sure that beam former completely shields anode from filament. For instructions on correctly aligning the high-performance emitter, see section 4.4.
4	Ion gauge indicates a pressure burst when crucible is rotating.	(a) Water is leaking past the gun's quad ring.	(a) Replace quad ring. Remember to lubricate the new quad ring properly with Apiezon L or an equivalent product.
5	Crucible sticks or is difficult to rotate.	(a) Quad ring is inadequately lubricated. (b) Worn bearings in bearing housing assembly or drive shaft assembly.	(a) Replace quad ring. Remember to lubricate the new quad ring properly with Apiezon L or an equivalent product. (b) Check bearings and replace as necessary.

NO.	SYMPTOM	PROBABLE CAUSE	CORRECTION
		(c) Misaligned parts in bearing housing assembly.	(c) Remove the crucible mounting flange and the bearing housing assembly from the gun and disassemble the bearing housing assembly. Check the condition of its bearings, the pivot shaft, and the bronze washer that sandwiches the quad ring seated in the crucible mounting flange. Replace any parts that show signs of wear or damage and reassemble the source. When reassembling the bearing housing assembly, carefully follow the instructions provided in section 5.3.

6.6 POP TOP FEATURE NOT FUNCTIONING CORRECTLY

NO.	SYMPTOM	PROBABLE CAUSE	CORRECTION
1	Crucible cover (Top) does not go up.	(a) Air pressure is too low. (b) Electrical signal not getting to air solenoid valve. (c) Air solenoid valve is not functioning properly. (d) Crucible cover may be sticking.	(a) Check and adjust air pressure. (b) Check and correct signal problem. (c) Check valve for proper function and replace if necessary. (d) Check for misalignment or binding of the push rods. Adjust as needed. Check for debris caught between the cover and coil housing or push rods and coil housing. Clean as needed. Check for sticking between the cover and the coil housing. Add a small amount of molybdenum disulfide to areas that show sign of sticking.
2	Crucible cover (Top) does not go down.	(a) Air pressure is too low. (b) Electrical signal not getting to Air solenoid valve. (c) Air valve solenoid is not functioning properly. (d) Foreign object below source (spider plate) which is preventing mechanism from lowering.	(a) Check and adjust air pressure. (b) Check and correct signal problem. (c) Check valve for proper function and replace if necessary. (d) Remove foreign object.
3	Crucible cover (Top) goes up only part way.	(a) Bellows is damaged.	(a) Check for correct connection of the air lines. <i>Note: Applying air pressure to the vent will damage the bellows. Check for misalignment of components. Correct problem and replace bellows.</i>
4	Crucible cover (Top) goes down only part way.	(a) Bellows is damaged. (b) Foreign object below source (spider plate) which is preventing mechanism from lowering.	(a) Check for correct connection of the air lines. <i>Note: Applying air pressure to the vent will damage the bellows. Check for misalignment of components. Correct problem and replace bellows.</i> (b) Remove foreign object.

SECTION 7

ENGINEERING DRAWING AND PARTS LISTS

Included in this section provides are the following engineering drawings and parts lists:

- 626-4365 Drive base unit (i.e., source without cover, emitter, crucible)
- 0626-4365-0 Parts list for base unit

This documentation is intended to facilitate maintenance, troubleshooting, and the ordering of replacement parts. It covers the base unit minus emitter assemblies, crucibles, and crucible covers. For information on ordering these parts, refer to the data sheet for this product or to the latest Temescal Price List.

REVISION HISTORY				
REV	DESCRIPTION OF CHANGE	BY	DATE	APPROVED
A	INITIAL RELEASE	JAR	10/31/2000	MJ
B	ADDED POP TOP CONTROL LINE LABEL TABLE PER ECN# 10916	PS	2/3/2004	CK

NOTES UNLESS OTHERWISE SPECIFIED:

- SLOT ALL SCREWS FULL LENGTH AND APPLY A LIGHT COAT OF "ROCOL" TYPE DF5M OR EQUIV. MOLYDISULFIDE.
- APPLY A LIGHT COAT OF VACUUM GRADE GREASE TO O-RINGS. LIBERALLY COAT ALL FOUR GROOVES OF QUAD RING WITH VACUUM GRADE GREASE BEFORE INSTALLING.
- CHARGE MAGNET TO REQUIRED GAUSS. (MEASURED AT CENTER OF TOP SIDE OF MAGNET). PLACE MAGNET IN ASSEMBLY WITH POLARITY AS SHOWN. (POLARITY DEVIATION CAN CAUSE BEAM DAMAGE), AND CONDUCT BEAM TEST.
- STAMP SERIAL NO. ON BASE PLATE .19-.25 HIGH X .005-.015 DEEP.
- CLEAN ASSEMBLY AFTER BEAM CHECK AND PLACE IN POLY BAG WITH DESICCANT.
- INSTALL ITEM 60 IF THE CRUCIBLE IS 4 PCKT OR ITEM 61 IF THE CRUCIBLE IS 6 PCKT. PLACE UNUSED INSERTS. THUMB SCREW ITEM 48 AND CRUCIBLE INSTALLATION SCREWS ITEM 25 (12 EA) IN POLY BAG TO SHIP WITH SOURCE.
- FILAMENT LEADS, SPARE PARTS KIT AND WRENCH WITH SLEEVE ARE TO BE PACKAGED WITH ASSEMBLY IN SHIPPING BOX. INSTRUCTION MANUAL TO BE SHIPPED SEPARATELY.
- ASSEMBLE AND BAG SEPARATELY.
- THE EMITTER, CRUCIBLE AND CRUCIBLE COVER ARE SHOWN FOR REFERENCE ONLY.
- ALL DIMENSIONS SHOWN ARE FOR REFERENCE ONLY.
- IF USING SHIELDED BEARINGS, INSTALL WITH SHIELD TO THE OUTSIDE.
- PRESSURIZE WATER CIRCUIT WITH 60 PSI AIR. SET THE GAP BETWEEN SOURCE COVER AND THE TOP OF THE CRUCIBLE WEB TO BE .0005"-.005".
- APPLY "PARKER O LUBE" GENEROUSLY TO O-RING, INSIDE SURFACE OF CYLINDER, AND TO PISTON SHAFT (ALL METAL SURFACES OVER WHICH O-RING MUST SLIDE). DO NOT CONTAMINATE EXTERNAL SURFACES (VACUUM).
- SWITCHES ARE TO BE ADJUSTED AFTER INSTALLATION ONTO SOURCE TRAY. THE "TOP DOWN" SWITCH ARM MUST CONTACT THE SOURCE TRAY AND CHANGE STATE WHEN THE COVER FULLY CONTACTS THE COIL HOUSING. THE "TOP UP" SWITCH ARM MUST CONTACT THE MOUNTING STRAP AND CHANGE STATE WHEN THE COVER REACHES ITS HIGHEST POINT OF TRAVEL.

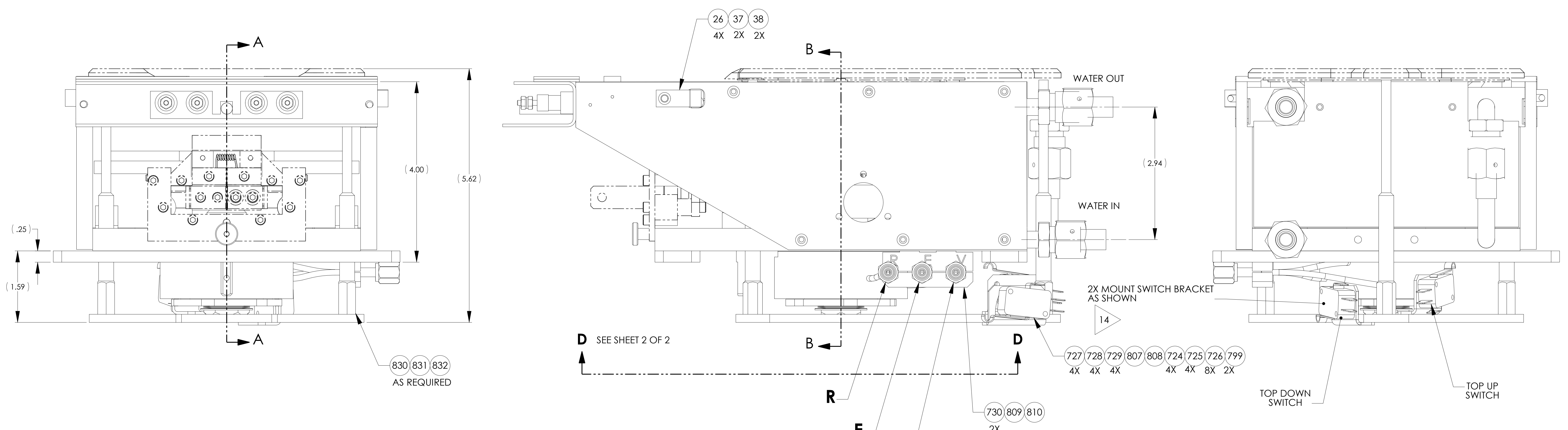

CRUCIBLE COVER CONTROL LINE LABELS	
R = RETRACT	TOP UP
E = EXTEND	TOP DOWN
V = VENT	VENT BELOW

APPLYING PRESSURIZED AIR TO V "V" LINE WILL DAMAGE POP TOP BELLOWS.

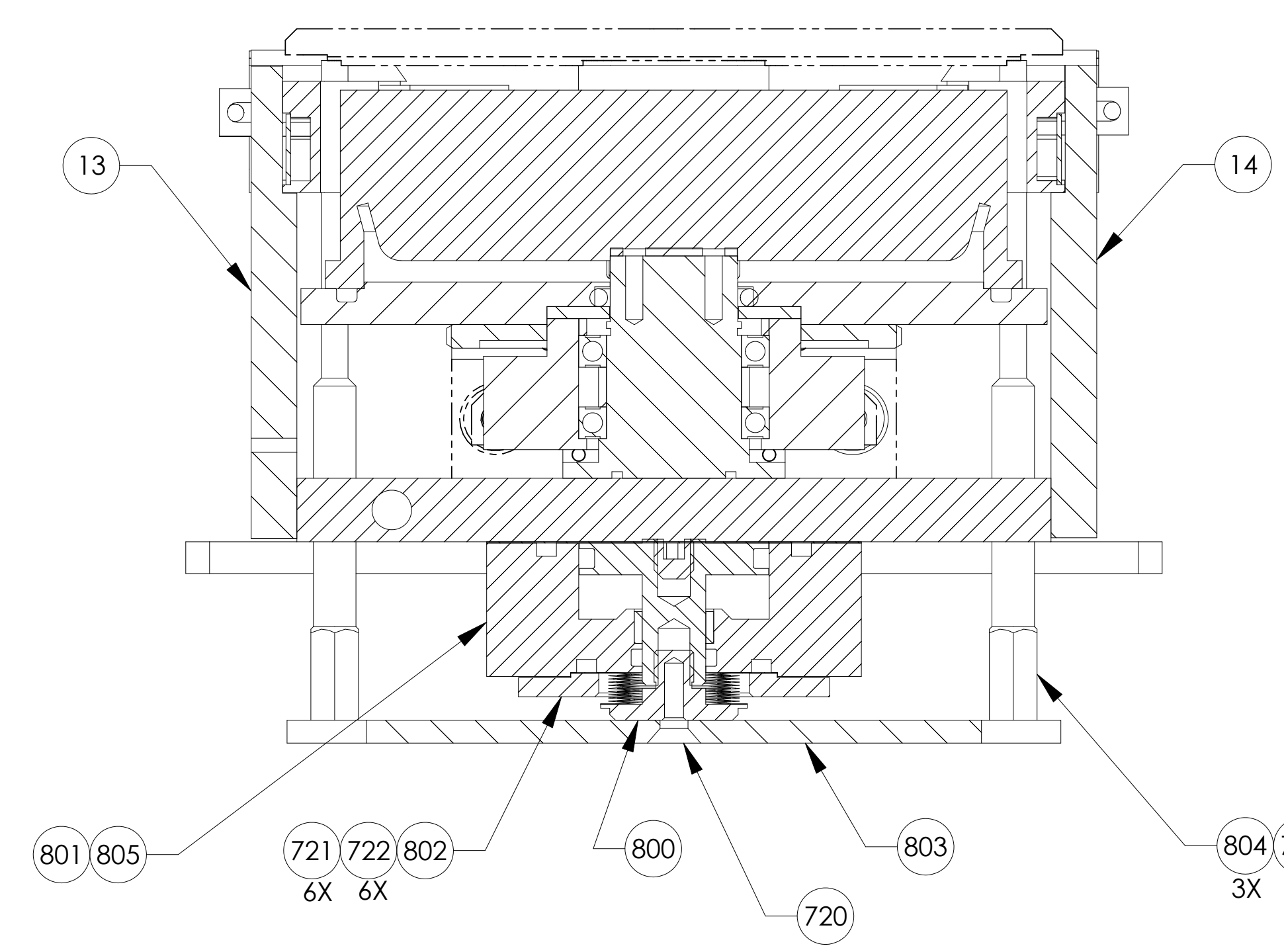
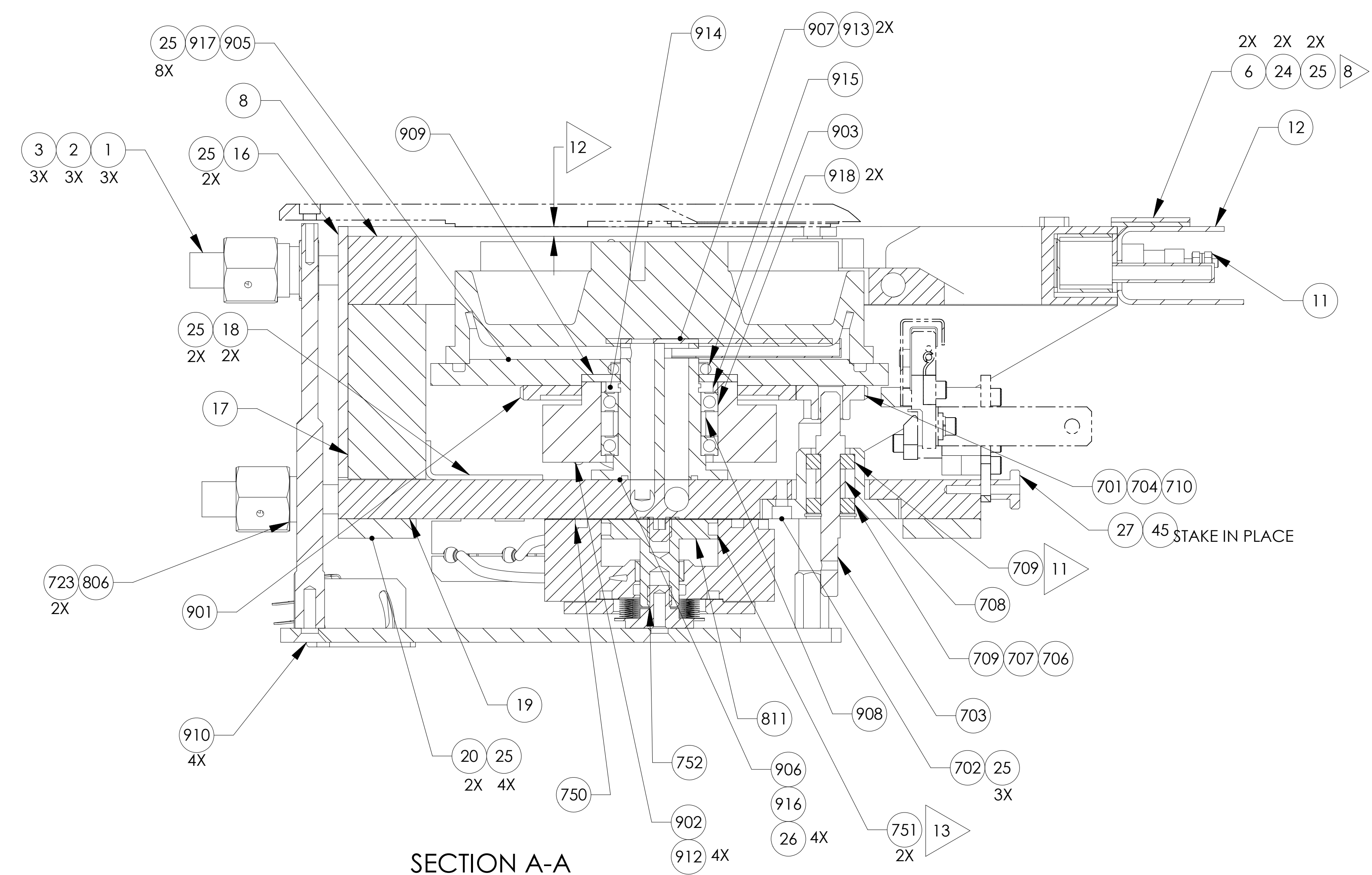

SECTION B-B

THIRD ANGLE PROJECTION	CAD GENERATED DRAWING DO NOT UPDATE MANUALLY		
UNLESS OTHERWISE SPECIFIED ALL DIMENSIONS ARE IN INCHES. TOLERANCES ARE: DECIMALS .005 .010 .015 .020 .030 .040 .050 .060 .070 .080 .090 .100 .150 .200 .300 .400 .500 .600 .700 .800 .900 1.000 1.500 2.000 3.000 4.000 5.000 6.000 8.000 10.000 ANGLES 15° 30° 45° 60° 90° 120° 150° 180°	APPROVALS JIM RHONE M. JENSEN	DATE 10/24/00	SOURCE ASSY, STIH-270-2CKB, POP-UP TYPE CASE CODE: 0626-4365 DWG. NO.: 0626-4365 SCALE: 1:1 SHEET: 1 OF 2

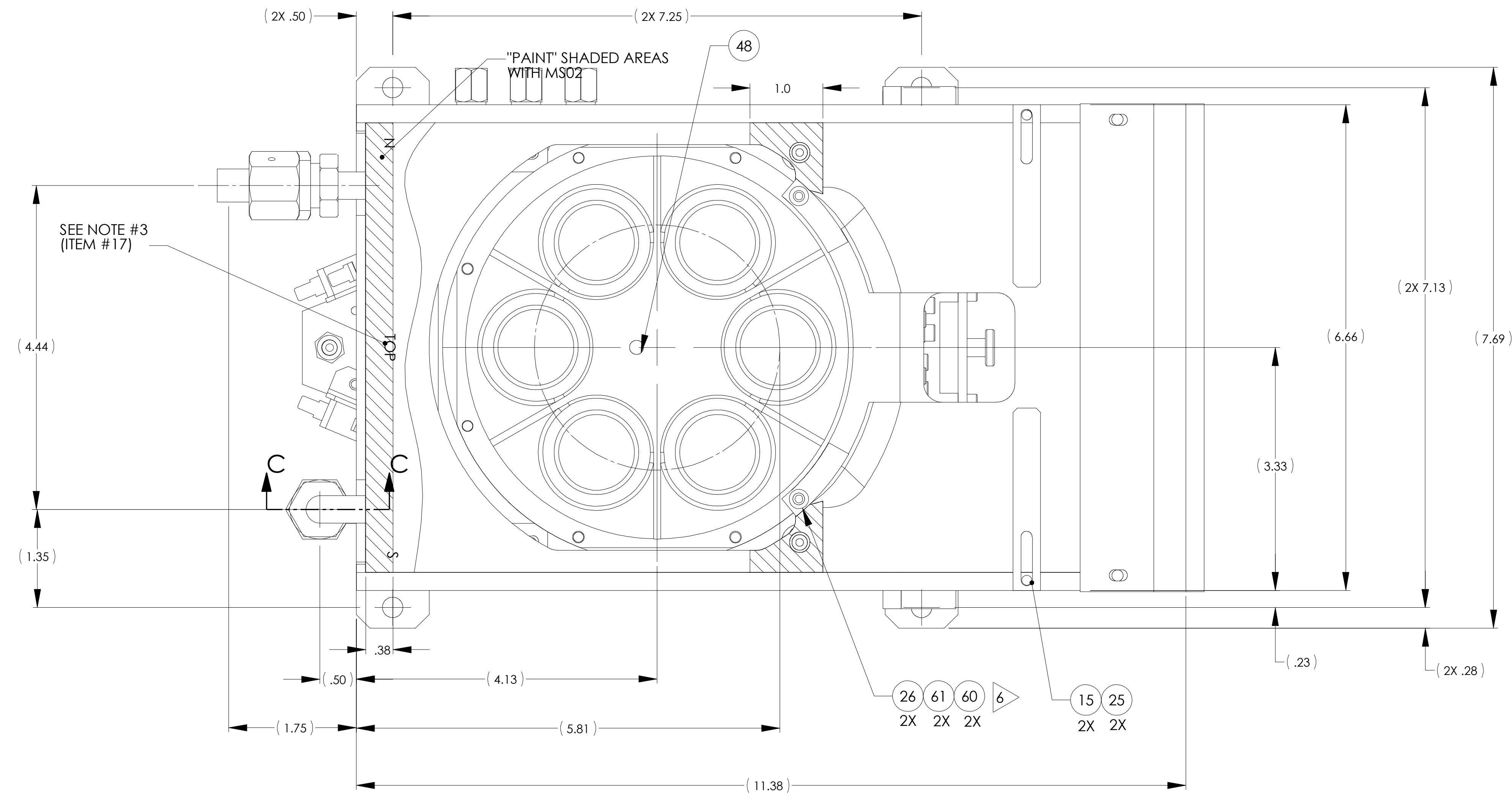

6 POCKET CONFIGURATION

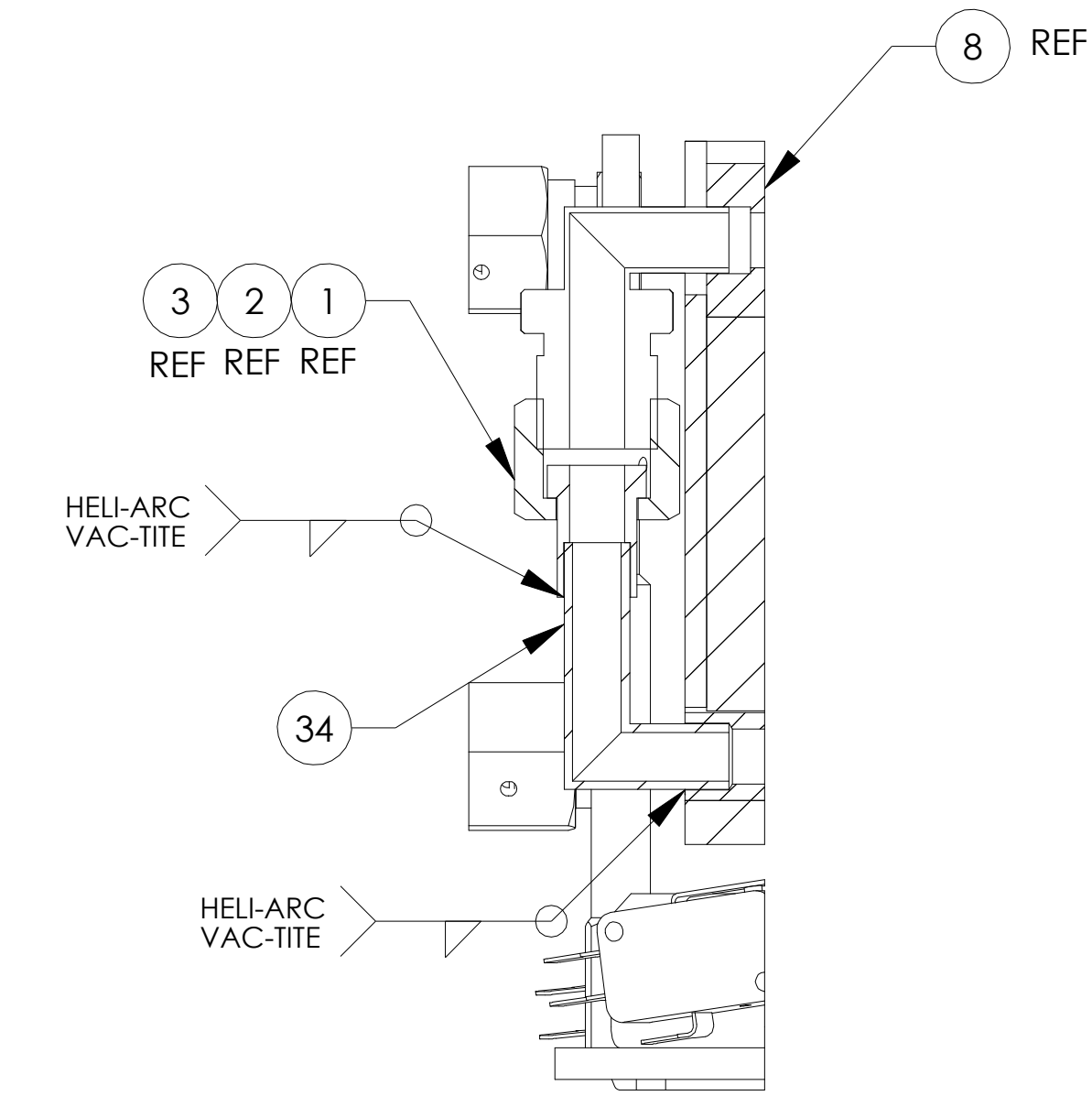

SECTION C-C

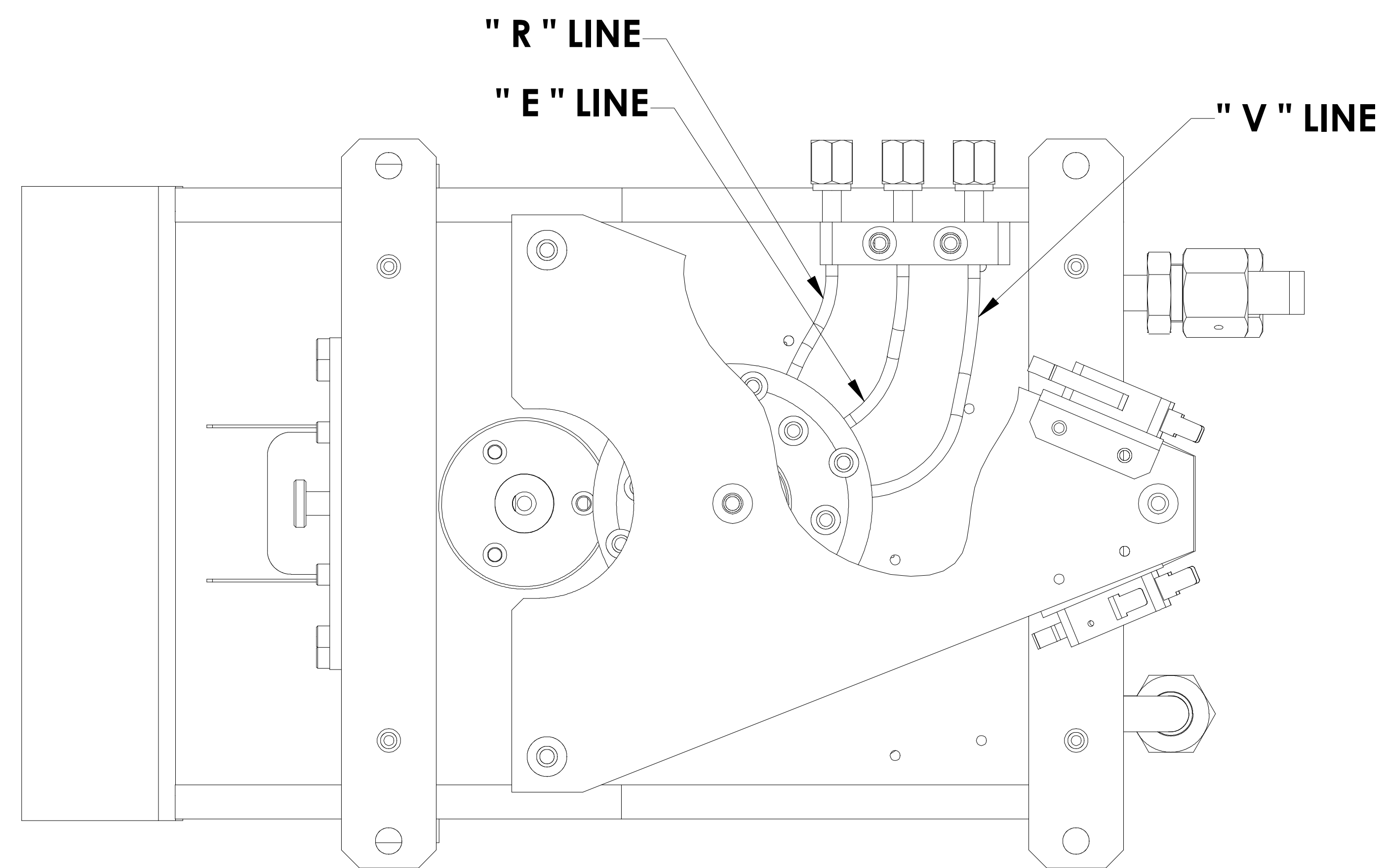
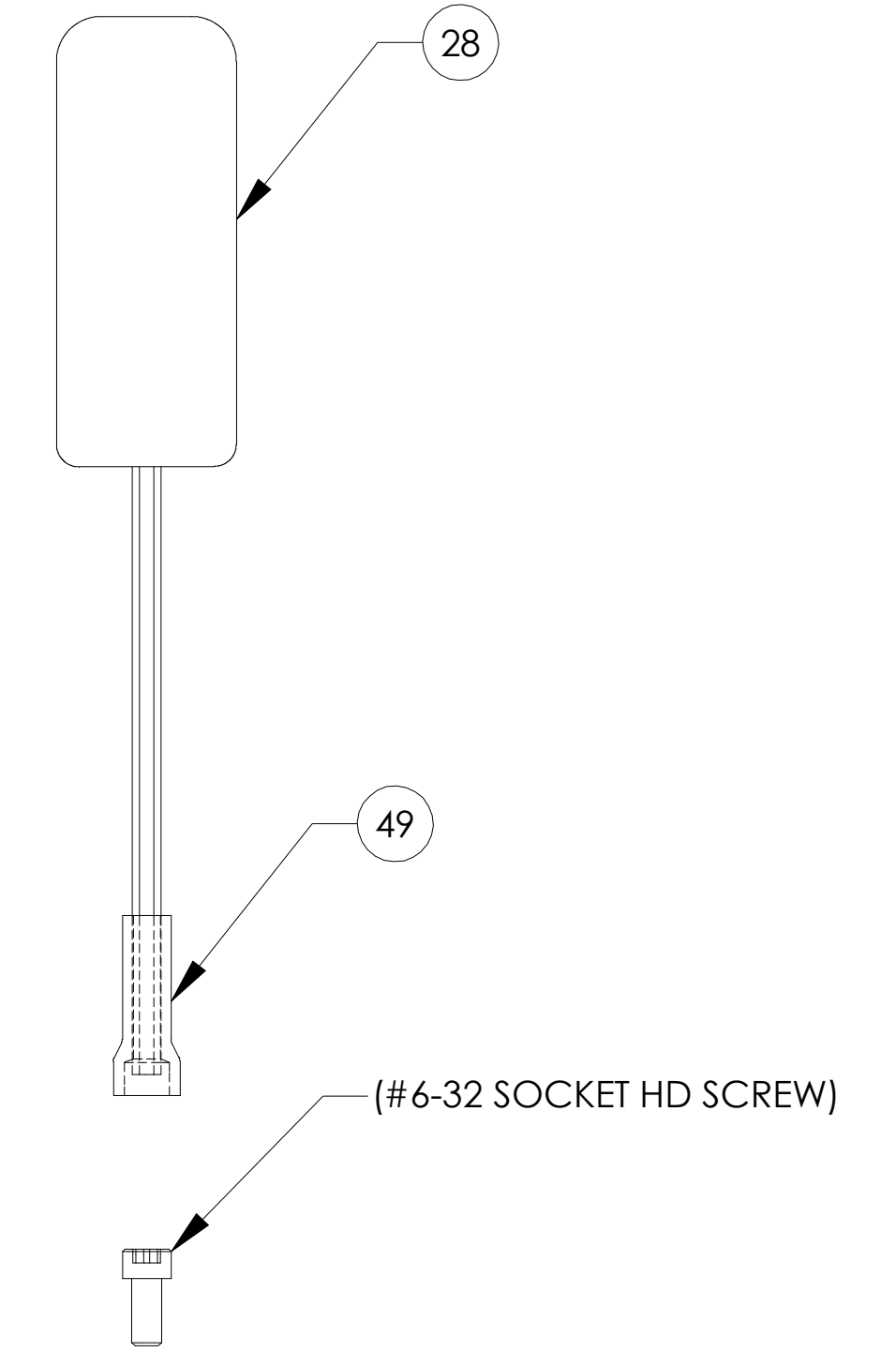

VIEW D

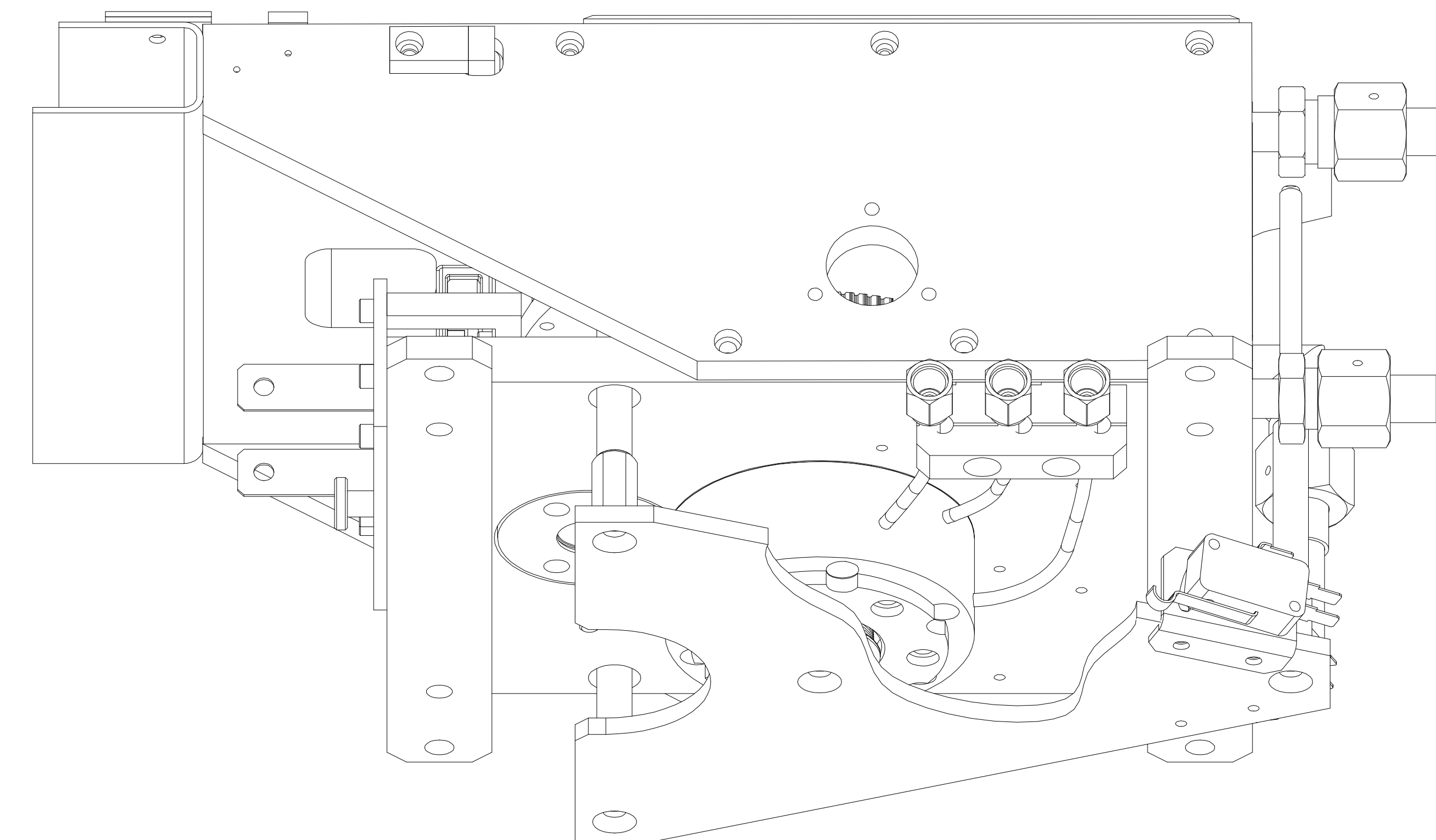

Engineering Drawing and Parts Lists

Parts List for Item Number 0626-4365-0

Single Level Bill :	By Ref#, [1 Line Desc, No Cost]	Date & Time:	04/03/06 10:15AM
			Temescal, Mapics ck
Parent Item Number:	0626-4365-0	SRC ASY,STIH-270-2CKB E,PT	
Drawing Number/Rev:	626-4365B	ENHANCED, BOT DR (BASE UNIT)	
		BEAM AT BACK OF POCKET AT 10KV	

REF#	ITEM NUMBER	DESCRIPTION	QTY	UM	DRAWING/REV
001	0420-1411-2	3/8 SOLDER NIPPLESST(TEME-FIT)	3.00	EA	420-1411-@
002	0420-0011-2	3/8 HEX NUT SST (TEME-FIT)	3.00	EA	420-0011A@
003	2231-0110-1	O-RING 3/8 ID X 3/32 W VITON	3.00	EA	
006	0214-9311-0	SHUNT BAR STIH-270-2C	4.00	EA	214-9311E@
008	0626-7434-0	COIL HOUSING,BRZMNT W/VCO PT	1.00	EA	626-7434A@
010	0303-3292-0	FILAMENT LEAD	2.00	EA	303-3292L
011	0312-6923-0	COIL ASSY	1.00	EA	312-6923E
012	0412-1452-0	COIL SHIELD STIH270-2C	1.00	EA	412-1452E@
013	0626-3784-1	POLE PIECE LH W/STEP,-2CKE	1.00	EA	626-3784B
014	0626-3784-2	POLE PIECE RH W/STEP,-2CKE	1.00	EA	626-3784B
015	0715-9412-3	POLE EXT, .38X2.50X.12 SST	2.00	EA	715-9412B@
016	0412-1482-1	MAGNET SHLD STIH2702 FOR -2 PT	1.00	EA	412-1482G
017	0413-3902-0	MAGNET STIH270-2M	1.00	EA	413-3902B
018	0030-1062-0	BRACKET,SINGLE MAGNET	2.00	EA	030-1062A@
019	0626-4355-0	BASE PLT FOR THE STIH270-2 PT	1.00	EA	626-4355D
020	0412-1542-0	MOUNTING STRAP STIH-2	2.00	EA	412-1542E@
022	0627-3050-0	SPARES KIT,-2CK/-3CK POPTOP	1.00	EA	627-3050B
024	1360-1200-0	NUT,HEX 6-32 SST	2.00	EA	
025	1321-1254-2	SCREW,SOC HD,THD VNT,6-32X.375	23.00	EA	
026	1321-1255-2	SCREW,SOC HD,THD VNT,6-32X.50	10.00	EA	
027	1371-4074-0	NUT,KNURLED 6-32 SST	1.00	EA	
028	6990-0015-0	BALL DRIVER,7/64 HEX	1.00	EA	
030	8130-1073-0	BOX CORR 19X9 1/4 X 6 3/8	1.00	EA	
031	0627-5264-2	INSERT,FOAM,RIGHT POPTOP	1.00	EA	627-5264B
032	0627-5264-1	INSERT,FOAM,LEFT POPTOP	1.00	EA	627-5264B
034	0204-3042-0	WATERLINE TUBING WELDMNT	1.00	EA	204-3042C@
037	0715-9212-0	BLOCK,MTG,POLE ADJUSTMNT SST	2.00	EA	715-9212A@
038	0715-9222-3	POLE EXT,INTERNAL,2.6LG SST	2.00	EA	715-9222B@
045	1311-1257-0	SCREW,S CUP 5 6-32X.750 304	1.00	EA	
046	8130-1073-5	SPACER 6 X 5 2	1.00	EA	
048	1349-4034-0	SCREW,THUMB 10-24X1" 3/4"HD	1.00	EA	

Engineering Drawing and Parts Lists

REF#	ITEM NUMBER	DESCRIPTION	QTY	UM	DRAWING/REV
049	0715-8272-0	SLEEVE,SCRW HLDNG,7/64" HX WR	1.00	EA	715-8272A
050	0626-4022-1	CRADLE,INSERT,MAG SHLD,-2/-3CK	1.00	EA	626-4022A@
051	0626-4022-2	CORNER,INSERT,MAG SHLD,-2/-3CK	4.00	EA	626-4022A@
052	0626-4022-3	TP,INSERT,MAG SHLD,-2/-3CK	1.00	EA	626-4022A@
053	0626-4022-4	SD CRNR,INSRT,MAG SHLD,-2/-3CK	2.00	EA	626-4022A@
054	0626-4022-5	ND CRNR,INSRT,MAG SHLD,-2/-3CK	2.00	EA	626-4022A@
060	0715-8173-1	INSERT,COIL HSG,X-CONT 4PKT -2	2.00	EA	715-8173B@
061	0715-8173-2	INSERT,COIL HSG,X-CONT 6PKT -2	2.00	EA	715-8173B@
701	0216-9192-0	PINION GEAR	1.00	EA	216-9192B@
702	0412-1402-0	DRIVE HOUSING STIH-270-2C	1.00	EA	412-1402D@
703	0216-9202-0	DRIVE SHAFT	1.00	EA	216-9202D@
704	1311-1250-0	SCREW,S CUP 5 6-32 X .125 SST	1.00	EA	
706	1384-0062-8	RING RETAINING TYPE 18-8 SST	1.00	EA	
707	1384-1032-5	RING RETAINING SST	1.00	EA	
708	9013-2814-0	SPACER,SHAFT .250 ID X .375 OD	1.00	EA	
709	9120-1271-0	BEARING,BALL .25ID X .62OD X .	2.00	EA	
710	1306-1256-0	ROLL PIN SPRING 3/32 DIA X 1/2	1.00	EA	
720	1321-1555-4	SCREW,FLAT HD SOC,10-32X.50	4.00	EA	
721	1321-1459-2	SCREW,SOC HD,THD VNT,8-32X1.00	6.00	EA	
722	1321-1454-3	SCREW,BUTTON HD SOC 8-32X.375	6.00	EA	
723	1321-1510-0	SCREW,SOC HD,THD VNT,10-32X1.0	2.00	EA	
724	1321-1253-2	SCREW,SOC HD,THD VNT,6-32X.312	4.00	EA	
725	1373-1200-0	WASHER,SPRING LOCK #6 SST	4.00	EA	
726	1377-1200-0	WASHER,FLAT SAE #6 SST	8.00	EA	
727	1321-0857-1	SCREW,SOC HD,THD VNT,4-40X.75	4.00	EA	
728	1360-0800-0	NUT,HEX 4-40 SST	4.00	EA	
729	1377-1053-1	WASHER,CRESCENT 4-40 BERYLIUM	4.00	EA	
730	1321-1459-2	SCREW,SOC HD,THD VNT,8-32X1.00	6.00	EA	
750	2231-0225-1	O-RING,1.859 I.D. X 1/8 CS	1.00	EA	
751	2231-0218-1	O-RING,1.234 I.D. X 1/8 CS	2.00	EA	
752	2231-0112-0	O-RING,1/2 (.487) ID X 3/32 CS	1.00	EA	
799	6156-1210-0	SWITCH,SIMULATED ROLLER LEVER	2.00	EA	
800	0627-2613-0	WELDMENT,BELLOWS,SST,POPTOP	1.00	EA	627-2613B
801	0627-2663-0	WELDMENT CYLINDER,PNEUMATIC	1.00	EA	627-2663A@
802	0627-2652-0	CLAMP,RING,BELLOWS SST	1.00	EA	627-2652B
803	0627-4833-0	PLATE,SPIDER, SST,POP TOP	1.00	EA	627-4833A
804	0627-4812-0	PUSHROD,SOLID, -2CK PT SRC	3.00	EA	627-4812A@
805	0627-2632-0	DISK,SEALING,SST, POPTOP	1.00	EA	627-2632A@

Engineering Drawing and Parts Lists

REF#	ITEM NUMBER	DESCRIPTION	QTY	UM	DRAWING/REV
806	0627-2702-0	BLOCK,GUIDE, VESPEL	1.00	EA	627-2702B
807	0627-2742-0	BRACKET,LIMIT SW,RH,POPTOP	1.00	EA	627-2742C
808	0627-2752-0	BRACKET,LIMIT SW,LH,POPTOP	1.00	EA	627-2752B
809	0627-2722-0	BLOCK,CLAMP,VCR BASE,POPTOP	1.00	EA	627-2722B
810	0627-2732-0	BLOCK,CLAMP,VCR CAP, POPTOP	1.00	EA	627-2732B@
811	0627-2782-0	PISTON, PNEUMATIC 1.490 OD	1.00	EA	627-2782A
830	9013-2802-0	SPACER,SHAFT .25ID.38OD.004 SST	3.00	EA	
831	9013-2806-0	SPACER,SHAFT .250 ID X .375 OD	3.00	EA	
832	9013-2813-0	SPACER,SHAFT .250 ID X .375 OD	3.00	EA	
833	1311-2153-0	SCREW,SET SOC CUP 5/16-24X.312	1.00	EA	
901	0503-2762-0	GEAR MODIFICATION	1.00	EA	503-2762A
902	0214-9272-0	BEARING HOUSING MTG FL	1.00	EA	214-9272B@
903	0214-9281-0	SPACER STIH-270-3	1.00	EA	214-9281A
905	0412-1323-0	CRUCIBLE MTG FLANGE	1.00	EA	412-1323E@
906	0412-1333-0	PIVOT SHAFT STIH270-2,SPECIAL	1.00	EA	412-1333J@
907	0412-1342-0	WATER BAFFLE ASSY STIH2	1.00	EA	412-1342G@
908	0412-1381-0	BEARING SPACER STIH-2	1.00	EA	412-1381B
909	0414-5712-1	WASHER FLT BKUP QD RNG,BRONZE	1.00	EA	414-5712C@
910	1321-1252-2	SCREW,SOC HD,THD VNT,6-32X.25	4.00	EA	
912	1321-1256-2	SCREW,SOC HD,THD VNT,6-32X.625	4.00	EA	
913	1340-1452-0T	SCREW,M BIND 2 8-32 X .250 SST	2.00	EA	
914	1384-1106-0	RING RETAINING SST	1.00	EA	
915	2108-0215-0	RING QUAD 1-1/16(1.046)ID X 1/	1.00	EA	
916	2231-0019-0	O-RING,.801(13/16) ID X 1/16 C	1.00	EA	
917	2231-0250-0	O-RING 5 ID X 1/8 W VIT	1.00	EA	
918	9120-1724-0	BEARING 17-24 TSNF SST	2.00	EA	
919	0101-9007-0	CD OF STIH-270-1CK, 2CK, 3CK,	1.00	EA	